

SERIES 2000A DOUBLE HUNG WINDOWS

TEST SIZE W x H	AAMA RATING	AIR INFILTRATION	DESIGN PRESSURE	WATER RESISTANCE	U-VALUE	SHGC	VT
56" x 91"	CW-PG50	≤0.30 cfm/ft ²	50 psf	7.5 psf	0.37-0.60	0.17-0.60	0.31-0.62

TABLE OF CONTENT

- INTRODUCTION -P1
- SECTION DETAILS -P2
- MULLION -P3-P4
- NAIL FIN -P5
- FACE FLANGE -P6-P7
- TRIPLE GLAZING -P7
- A/C ORIEL KIT -P8-P9

FEATURES

- ALUMINUM THERMAL-BREAK DOUBLE HUNG TILT WINDOW
- 3-1/4" FRAME DEPTH
- 7/8" DOUBLE PANE INSULATED GLASS
- AAMA 2604 POWDER COAT PAINT
- EQUAL SIGHTLINE DESIGN
- SLOPED SILL
- SILL WITH 1/2" EXTERIOR LEG
- TILT SASH WITH TILT LATCH
- CONTINUOUS LIFT HANDLE ON BOTTOM SASH
- ANTI-DRIFT HEAD CLIP LOCK
- MEETING RAIL LOCK
- SPIRAL BALANCES
- INSTALLATION SCREWS

OPTIONAL SELECTIONS

- LOW-E COATING & ARGON FILLED IGU
- SILL WITH EQUAL LEG
- 1-1/4" NAILING FIN (1-1/8" SETBACK)
- FACE FLANGE WITH VARIOUS SIZE
- CUSTOM FINISH AND CUSTOM COLORS
- GRIDS
- BLOCK & TACKLE OR ULTRA LIFT BALANCES
- OTHER OPTIONAL ACCESSORIES
- A/C ORIEL KIT
- HALF OR FULL SCREEN
- SASH STOPS

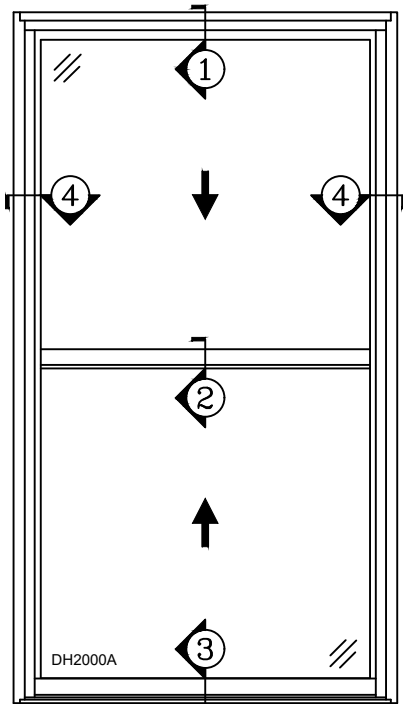

2000A DOUBLE HUNG

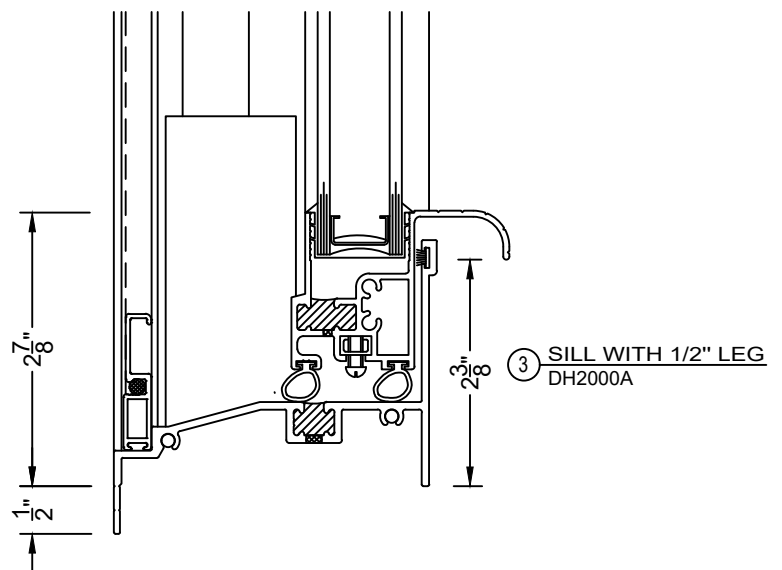
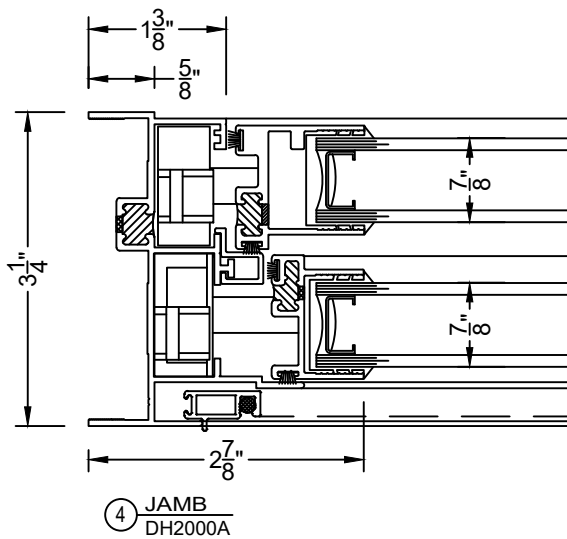
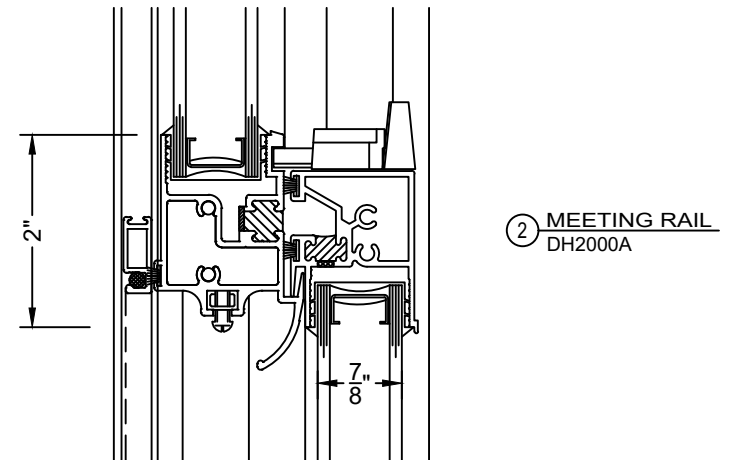
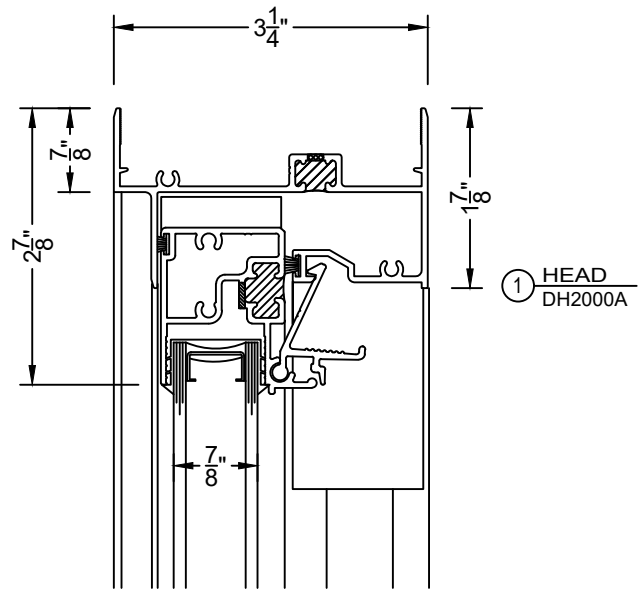

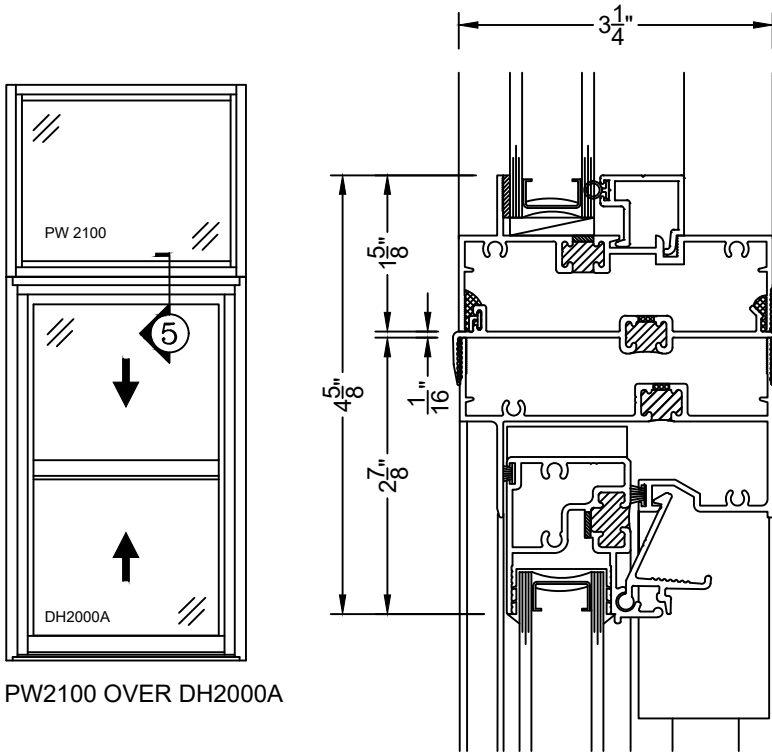

PW2100 OVER DH2000A

5 STACK MULLION
PW2100 OVER DH2000A

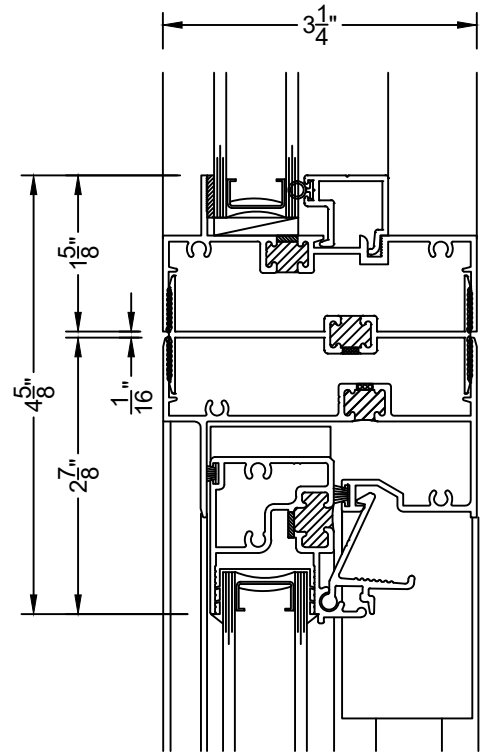

5A H MULLION
PW2100 OVER DH2000A

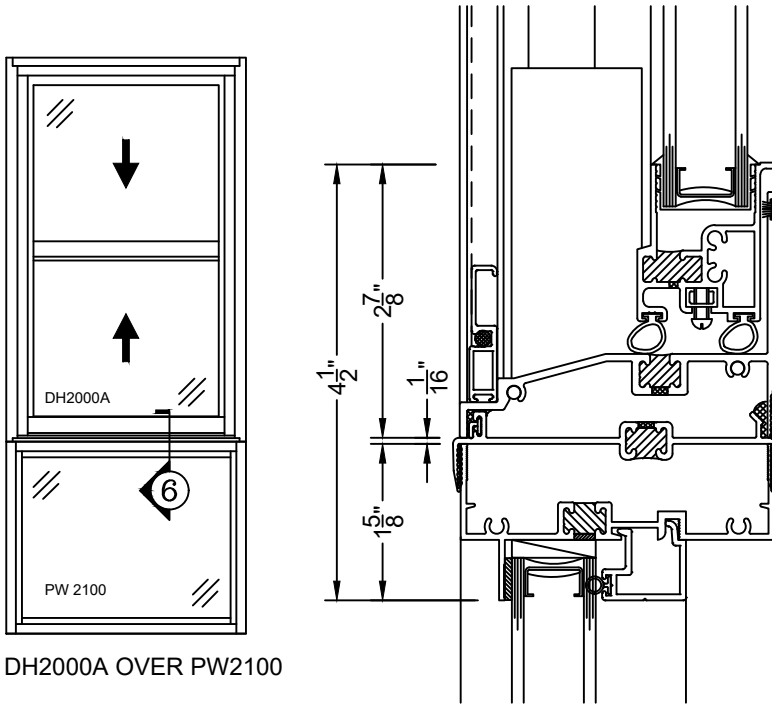

DH2000A OVER PW2100

6 STACK MULLION
DH2000A OVER PW2100

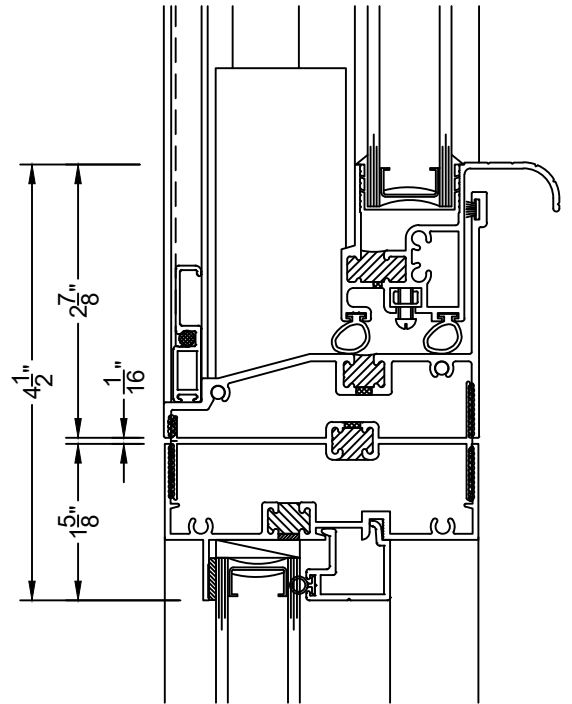

6A SHORT LEG H MULLION
DH2000A OVER PW2100

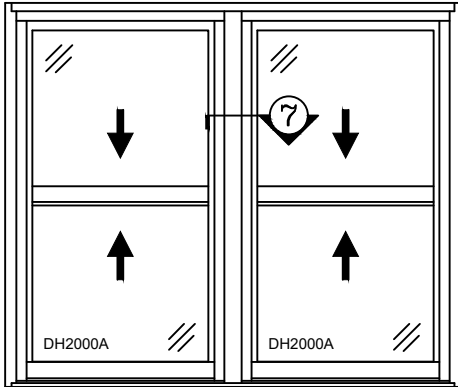

2000A TWIN DOUBLE HUNG

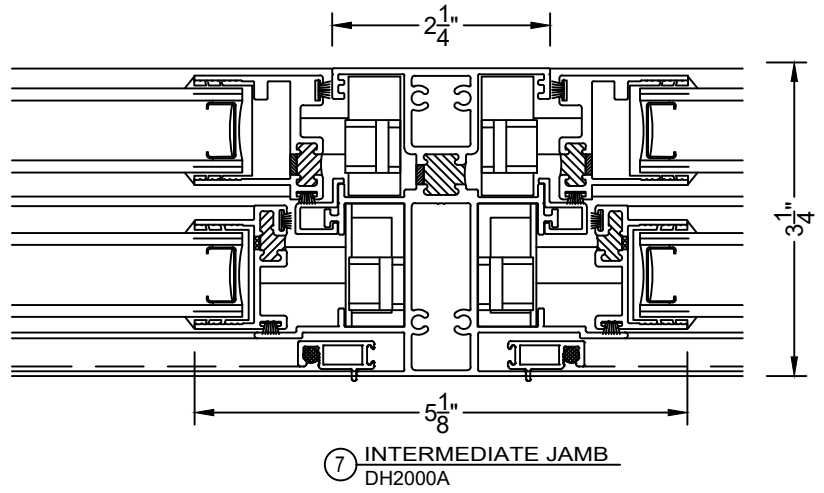

⑦ INTERMEDIATE JAMB
DH2000A

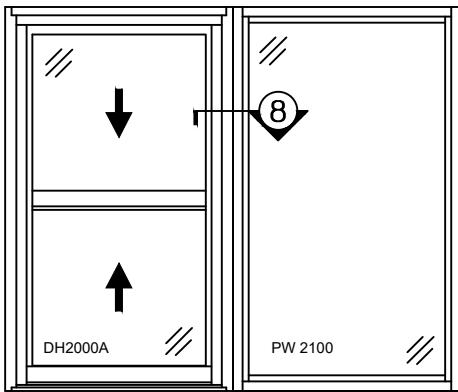

DH2000A & PW2100

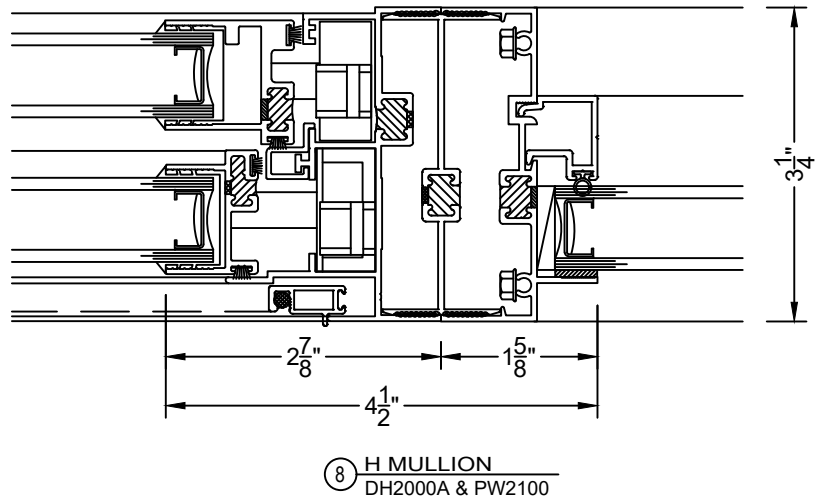

⑧ H MULLION
DH2000A & PW2100

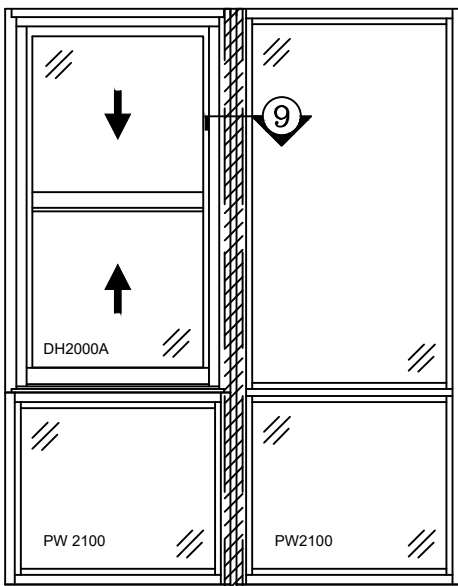

DH2000A OVER PW2100 &
PW2100T W/ 3PC MULLION

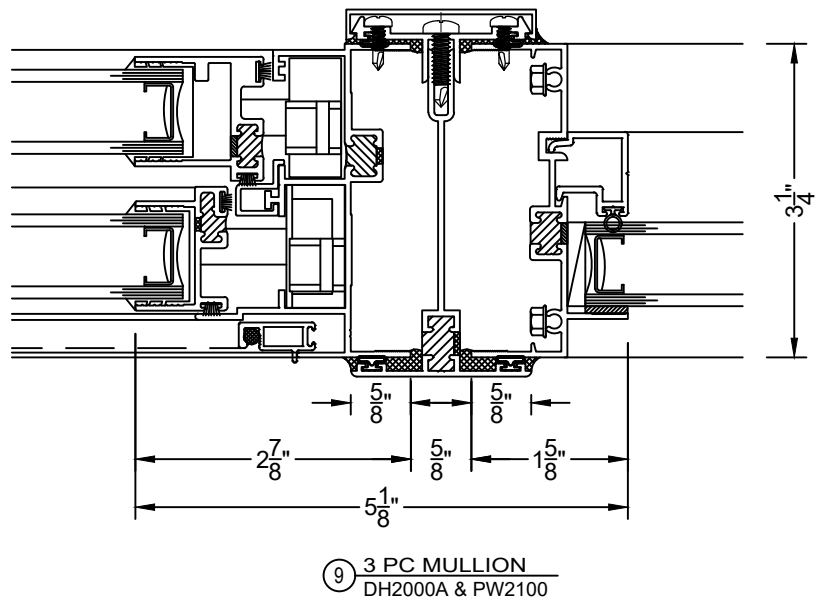

⑨ 3 PC MULLION
DH2000A & PW2100

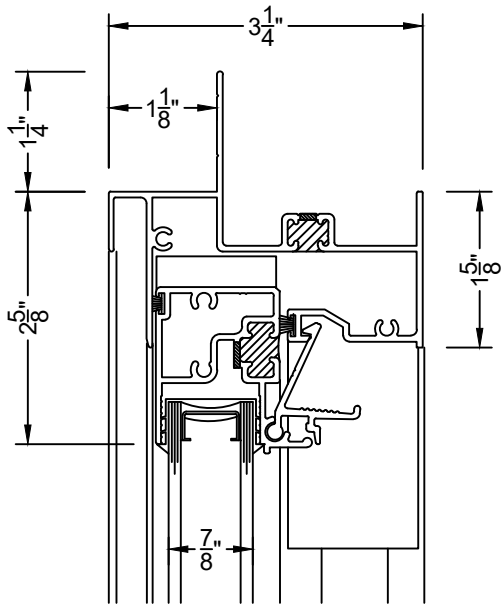

① NAILING FIN HEAD
DH2000A

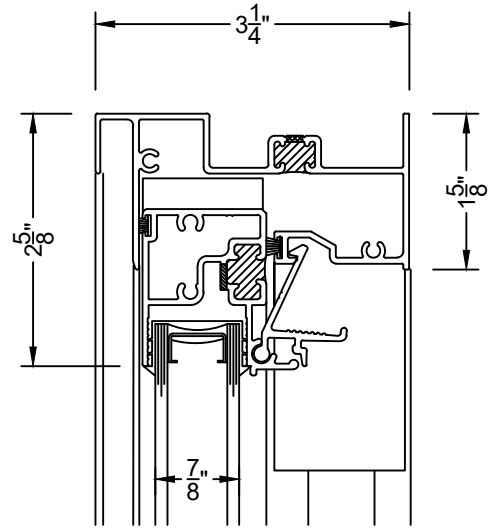

①A NAILING FIN HEAD W/O FIN
DH2000A

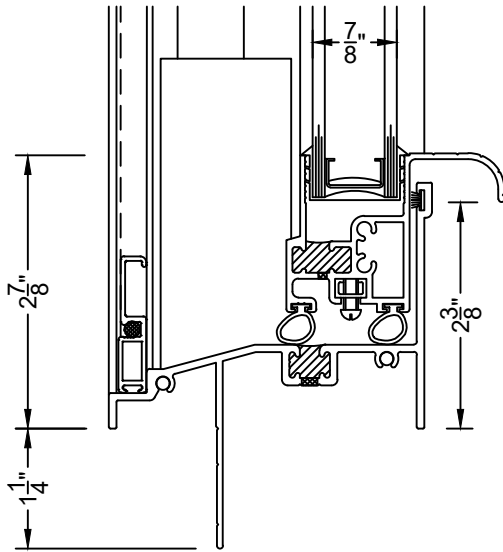

② NAILING FIN SILL
DH2000A

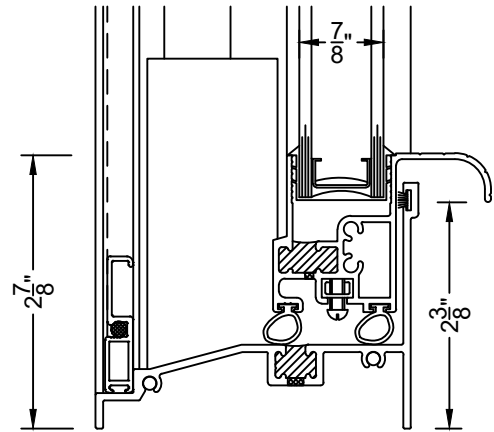

②A SILL WITH EQUAL LEG
DH2000A

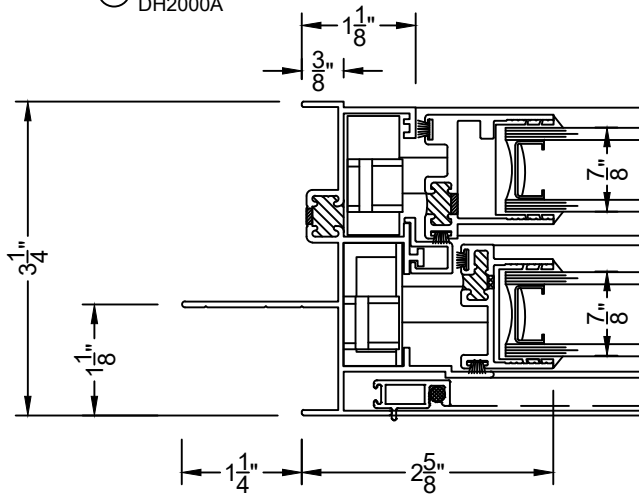

③ NAILING FIN JAMB
DH2000A

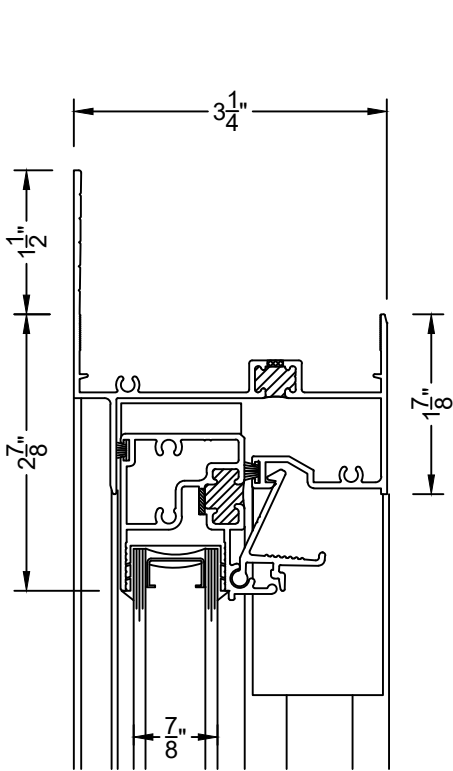

① 1-1/2" FLANGE HEAD
DH2000A

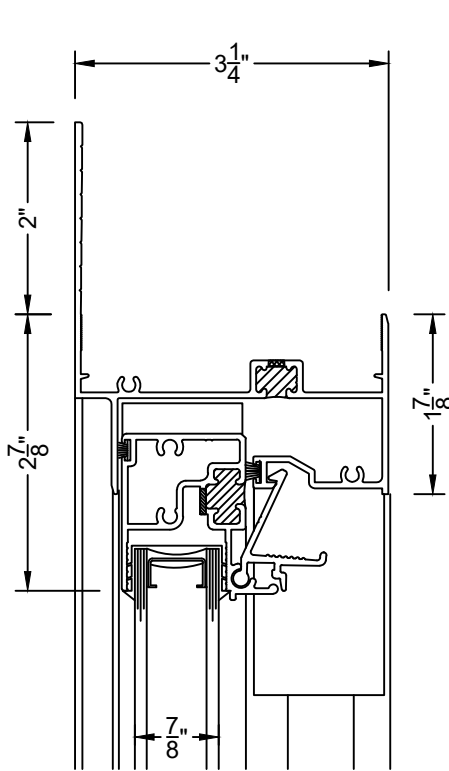

①A 2" FLANGE HEAD
DH2000A

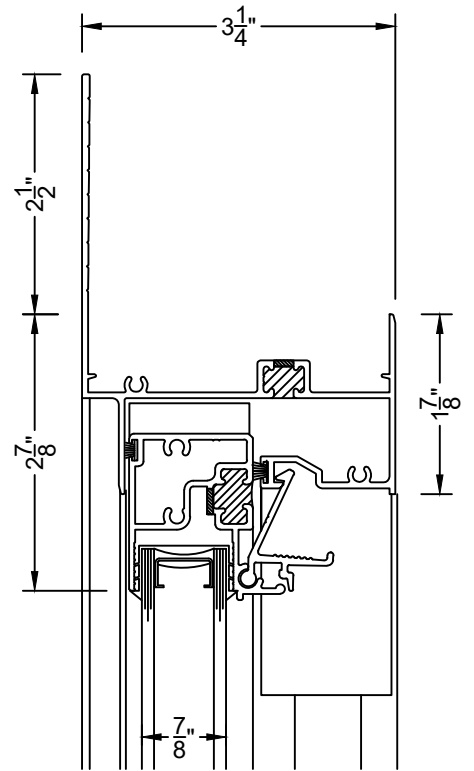

①B 2-1/2" FLANGE HEAD
DH2000A

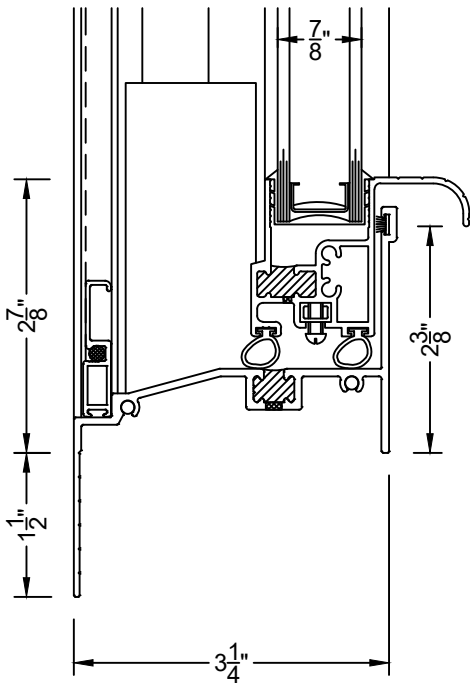

② 1-1/2" FLANGE SILL
DH2000A

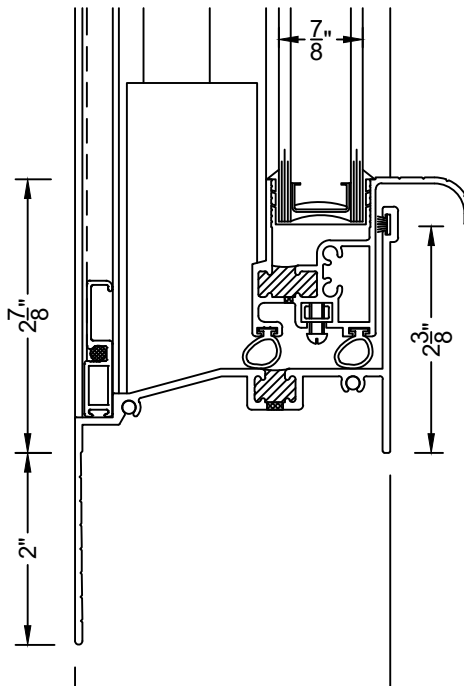

②A 2" FLANGE SILL
DH2000A

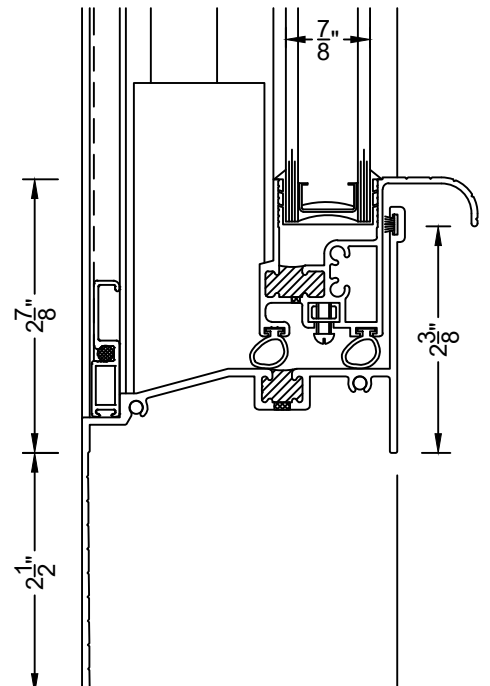

②B 2-1/2" FLANGE SILL
DH2000A

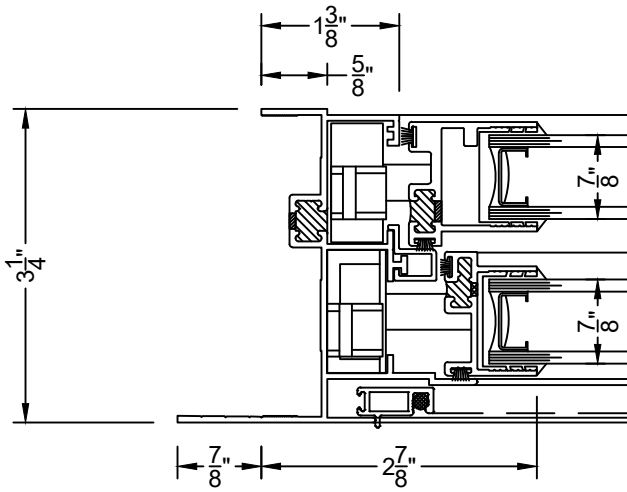

③ 7/8" FLANGE JAMB
DH2000A

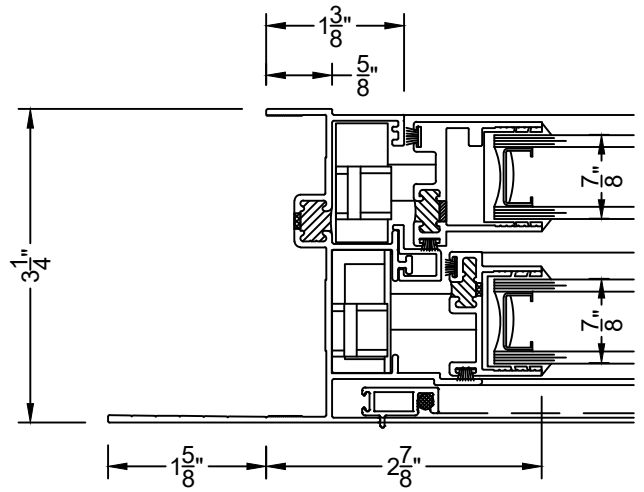

③B 1-5/8" FLANGE JAMB
DH2000A

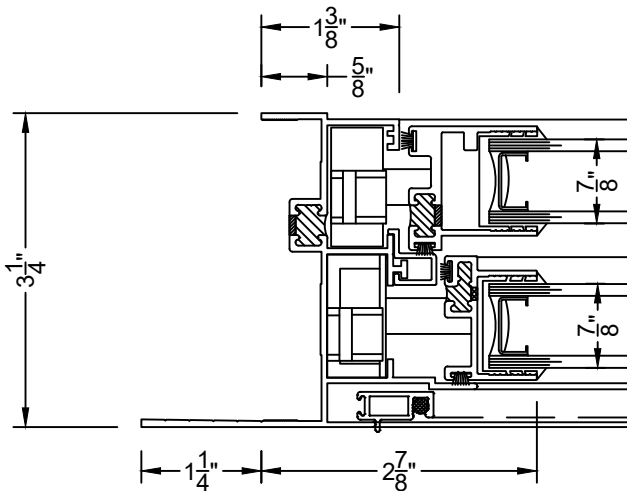

③A 1-1/4" FLANGE JAMB
DH2000A

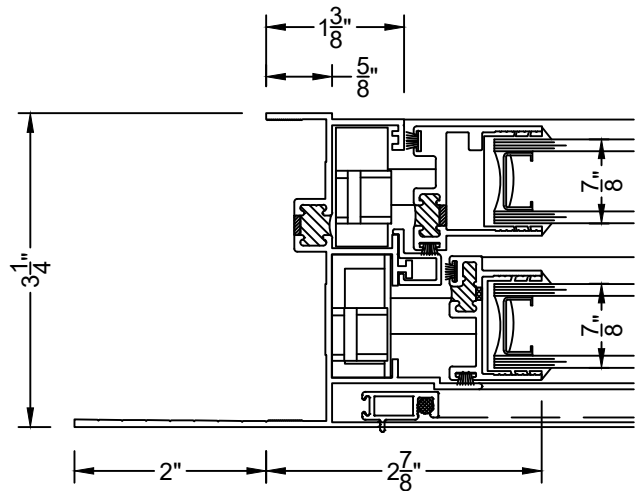

③C 2" FLANGE JAMB
DH2000A

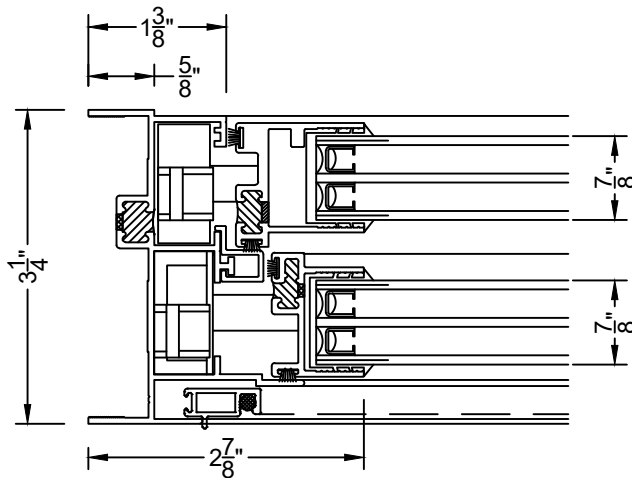

③D JAMB W/ TRIPLE GLAZING
DH2000A

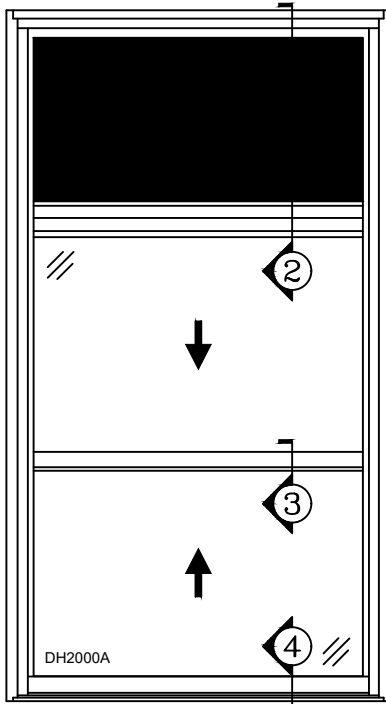

DH2000A WITH A/C ORIEL KIT AT TOP SASH

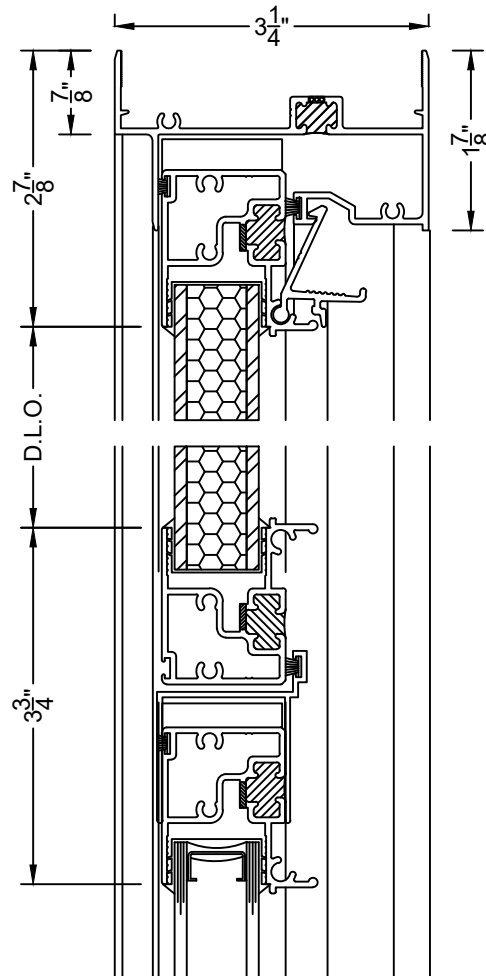

① HEAD
DH2000A

② AC KIT
DH2000A

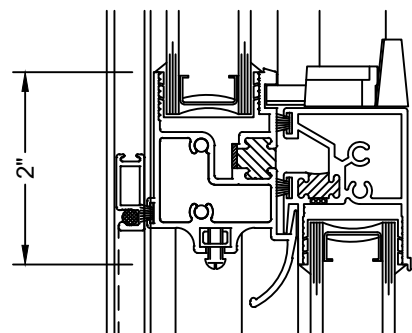

③ MEETING RAIL
DH2000A

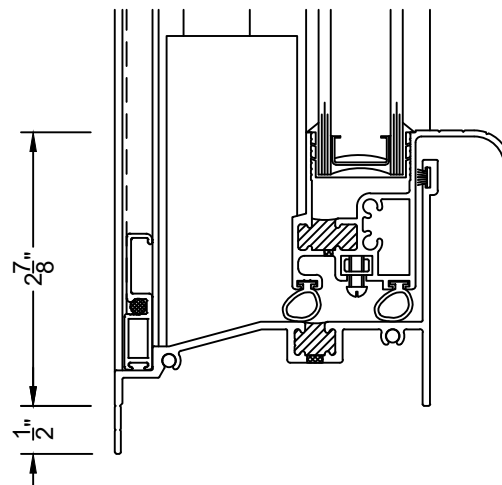

④ SILL
DH2000A

VER: 2020.03

NO WATER PERFORMANCE WARRANTY FOR A/C ORIEL KIT. PLEASE CONTACT YOUR SALE REP. FOR MORE INFORMATION.

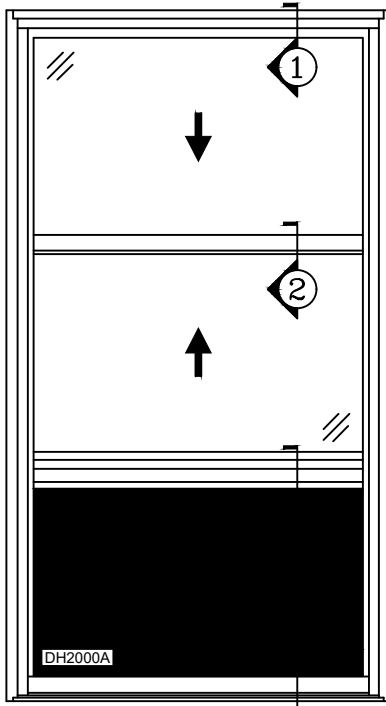

DH2000A WITH A/C ORIEL KIT
AT BOTTOM SASH

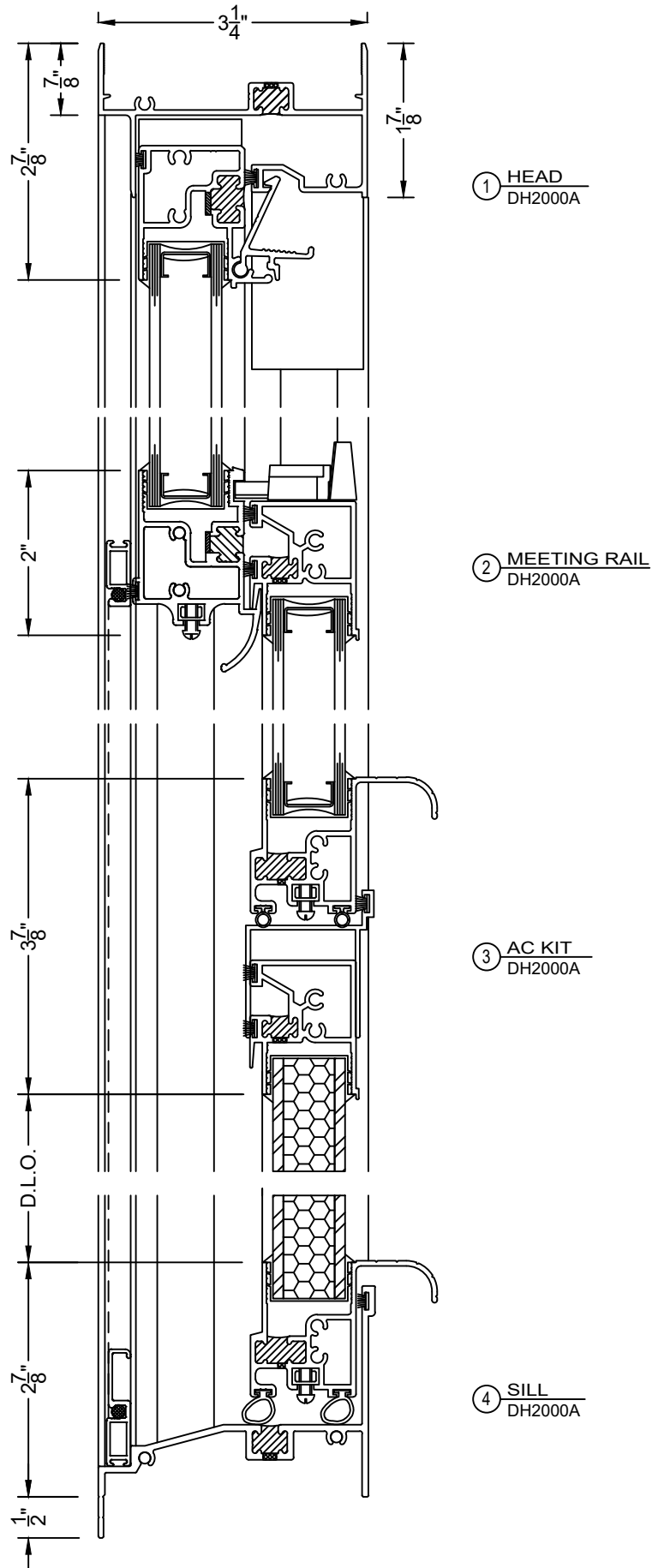

VER: 2020.03

NO WATER PERFORMANCE WARRANTY FOR A/C ORIEL KIT. PLEASE CONTACT YOUR SALE REP. FOR MORE INFORMATION.