

SERIES 5600 SLIDING WINDOWS

TEST SIZE W x H	AAMA RATING	AIR INFILTRATION	DESIGN PRESSURE	WATER RESISTANCE	U-VALUE	SHGC	VT
99" x 79" (TWO LITE)	AW-PG40	≤0.30 cfm/ft ²	40 psf	8 psf	0.41-0.64	0.17-0.56	0.23-0.59
108" x 60" (THREE LITE)	AW-PG50	≤0.30 cfm/ft ²	50 psf	10 psf			

TABLE OF CONTENT

- INTRODUCTION -P1
- TWO LITE SLIDER -P2
- THREE LITE SLIDER (OXO) -P3
- THREE LITE SLIDER (XOX) -P4
- MULLION -P5-P7
- NAILING FIN -P8
- FLANGE -P9-P11

FEATURES

- ALUMINUM THERMAL-BREAK HORIZONTAL SLIDING WINDOW
- 3-1/4" FRAME DEPTH
- 1" DOUBLE PANE INSULATED GLASS
- HEAVY DUTY EXTRUSION
- AAMA 2604 POWDER COAT PAINT
- CONTINUOUS FULL HEIGHT SASH CLIP LOCK
- DOUBLE MEETING RAIL INTERLOCK
- DUAL STAINLESS STEEL SASH ROLLERS
- STAINLESS STEEL REINFORCED FRAME ROLLER TRACK
- HALF SCREEN

OPTIONAL SELECTIONS

- LOW-E COATING & ARGON FILLED IGU
- 1-1/4" NAILING FIN
- FACE FLANGE WITH VARIOUS SIZE
- CUSTOM FINISH AND CUSTOM COLOR
- GRIDS
- VINYL OR METAL SASH STOP
- FULL SCREEN
- OTHER OPTIONAL ACCESSORIES

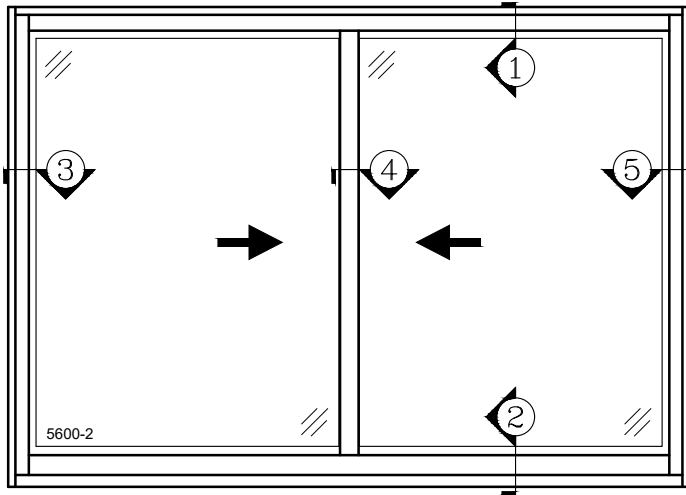

5600-2 TWO LITE SLIDER

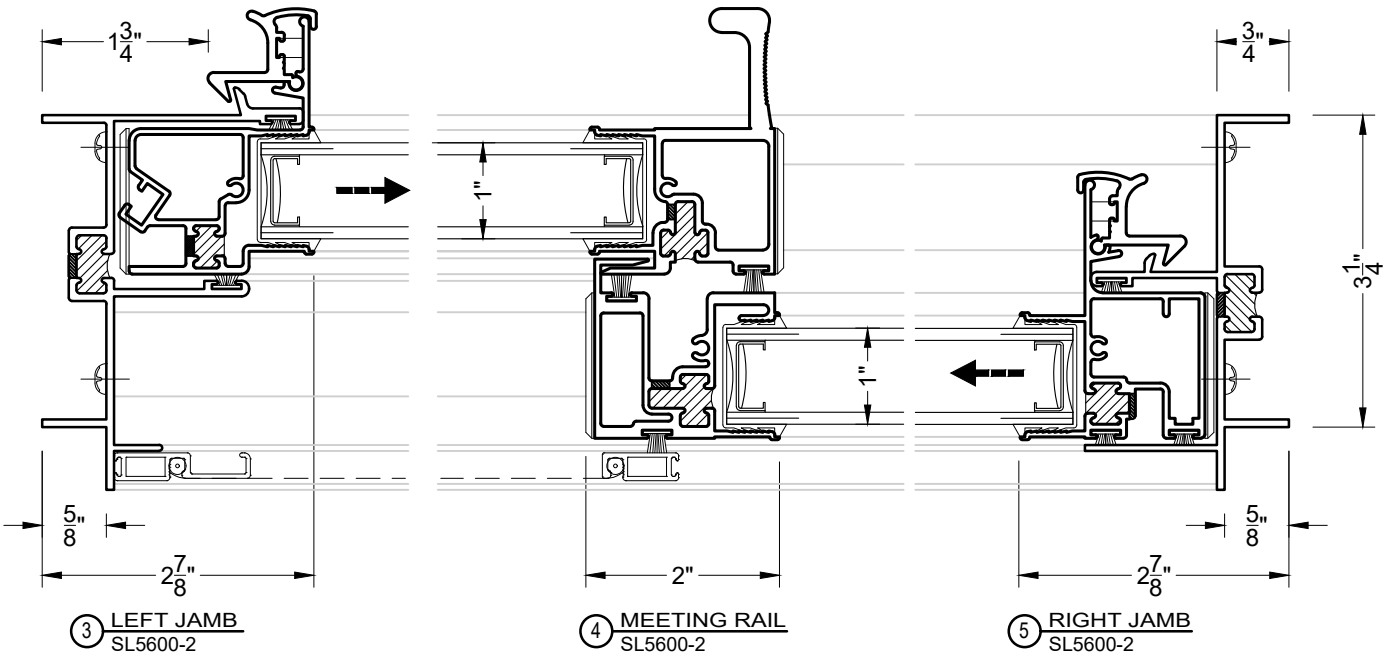
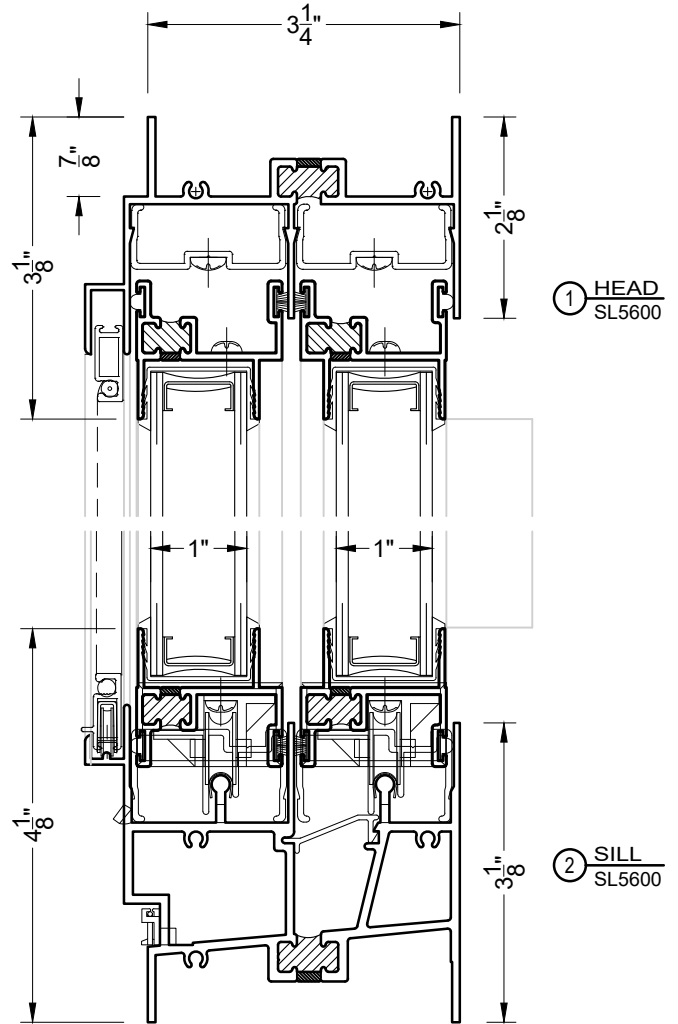

VER: 2022.08

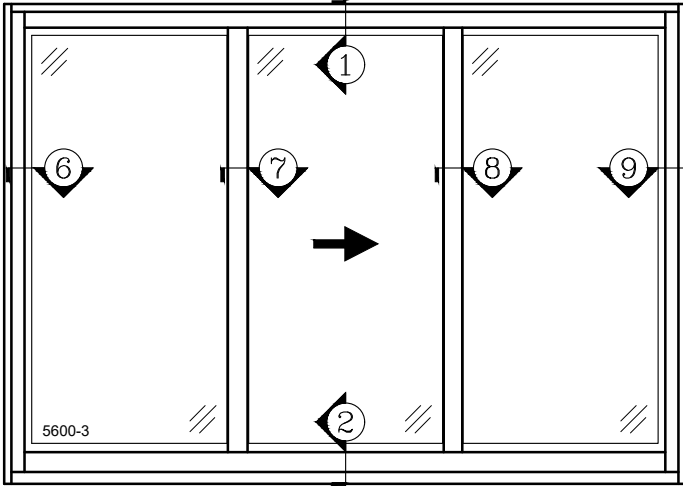

5600-3 THREE LITE SLIDER (O-X-O)

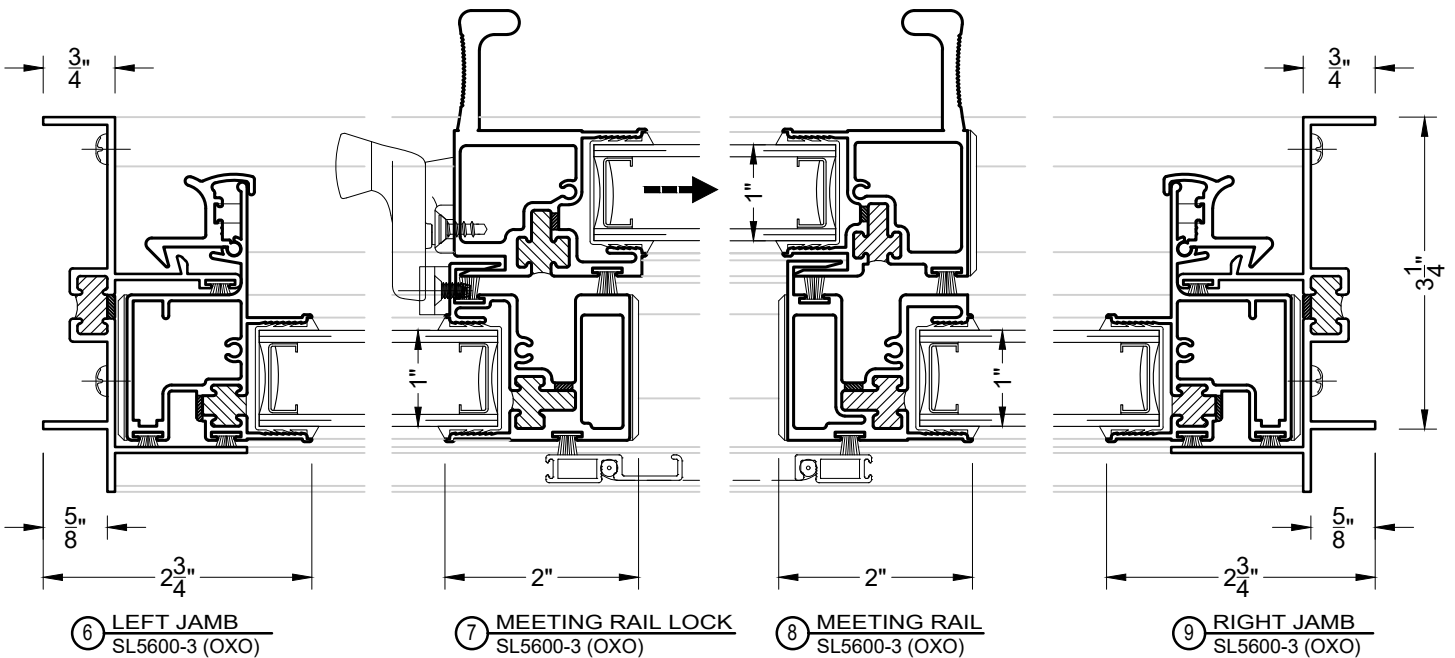
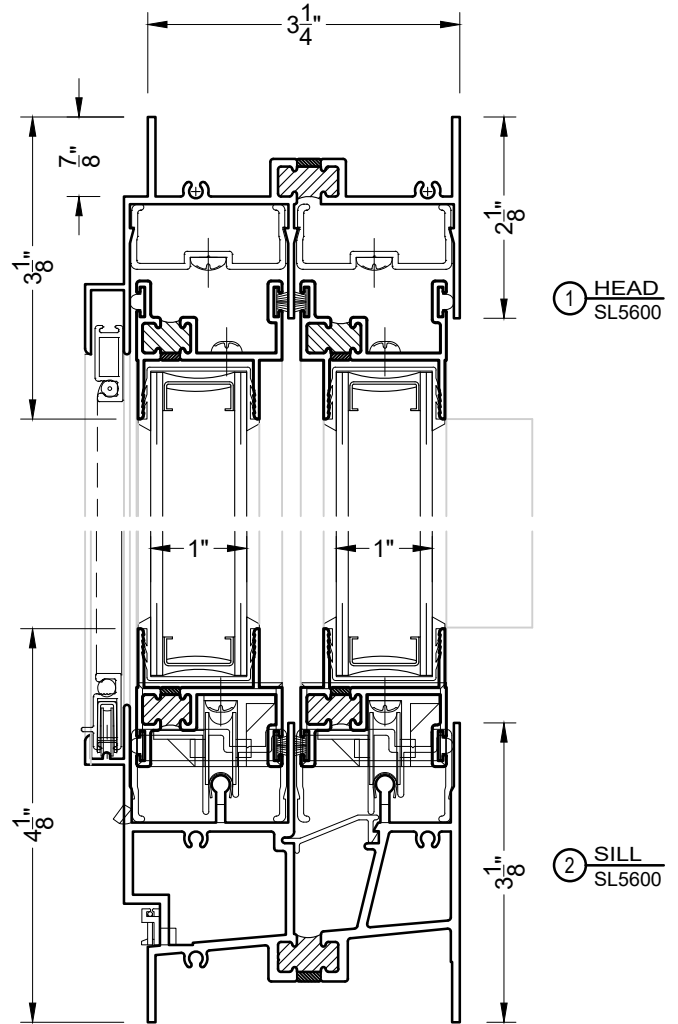

VER: 2022.08

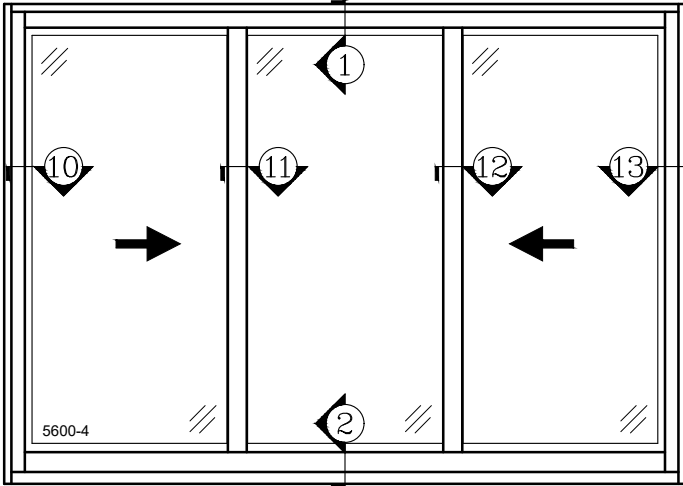

5600-4 THREE LITE SLIDER (X-O-X)

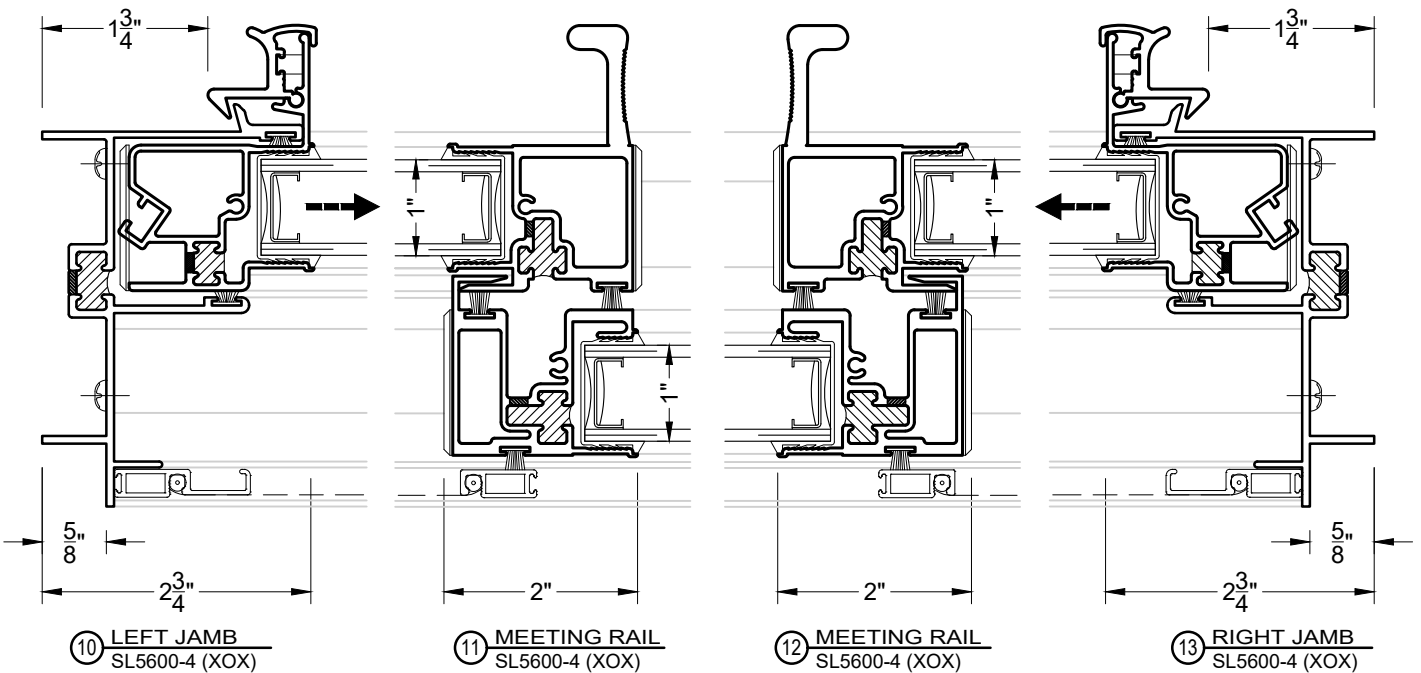
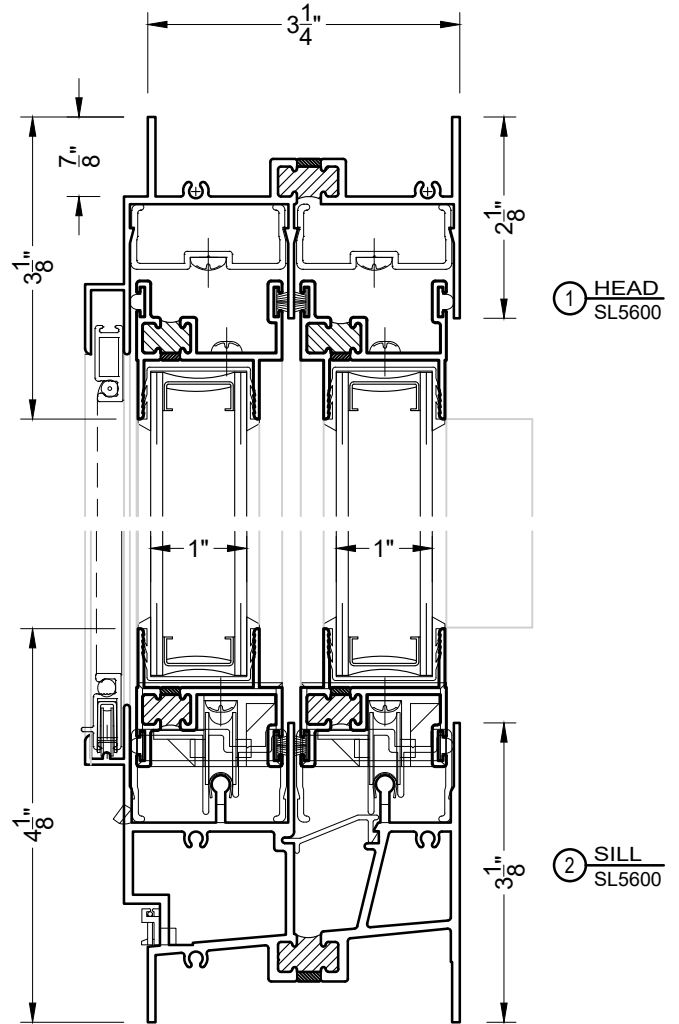

VER: 2022.08

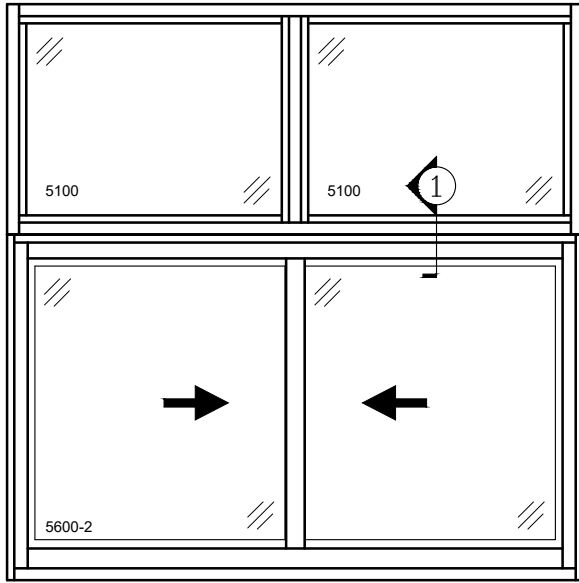

PW5100-2H OVER SL5600-2

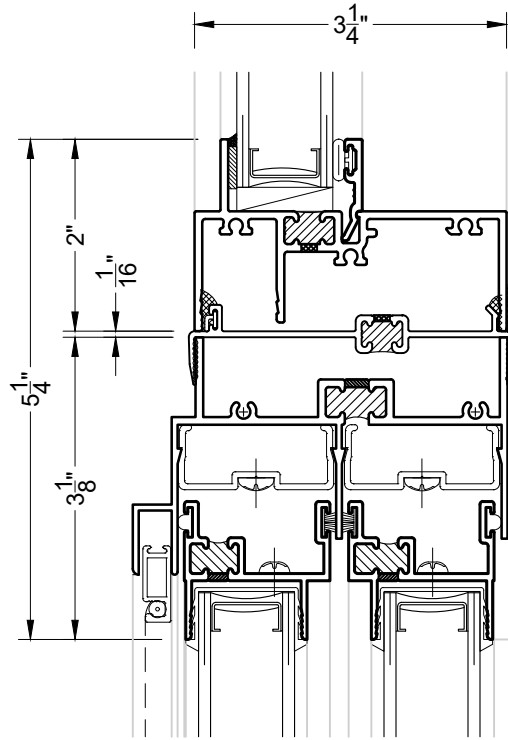

① **STACK MULLION**
 PW5100 OVER SL5600-2

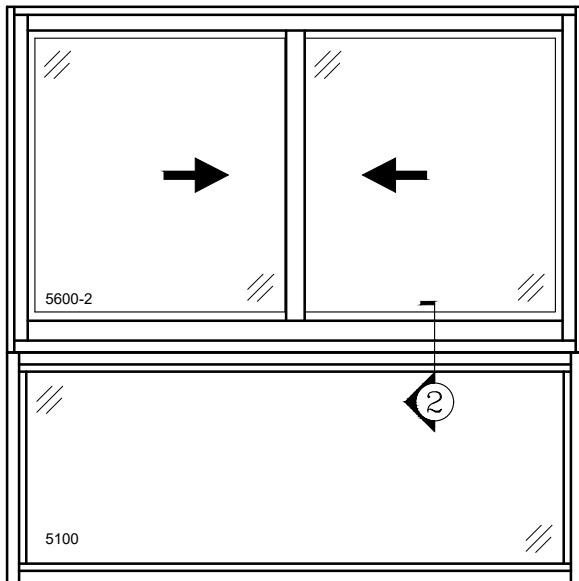

SL5600-2 OVER PW5100

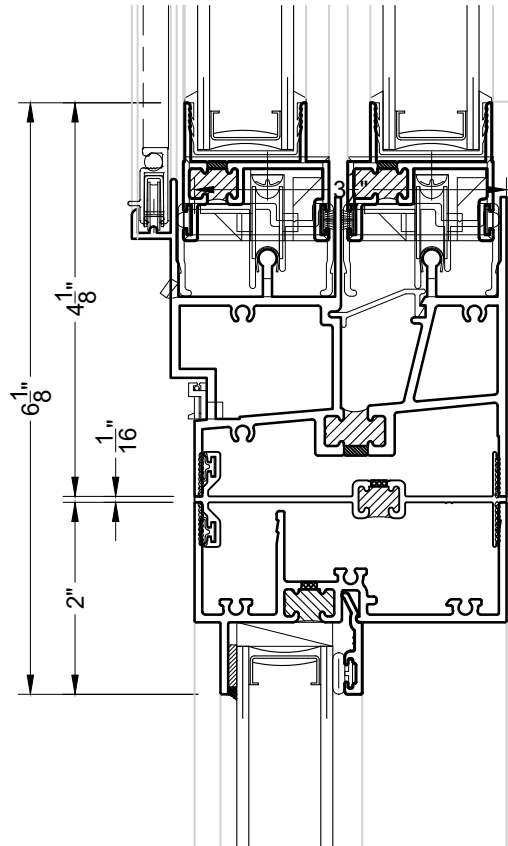

② **SHORT LEG H MULLION**
 SL5600-2 OVER PW5100

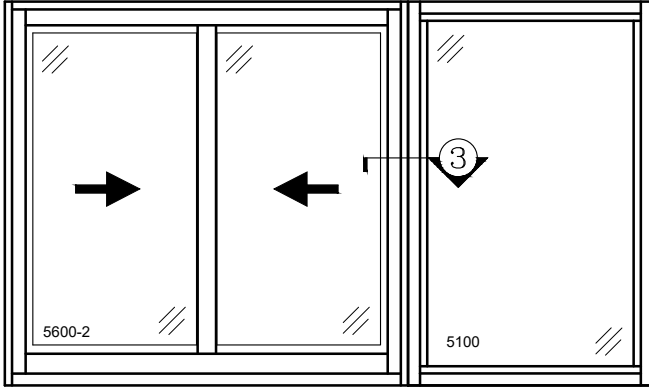

SL5600-2 & PW5100

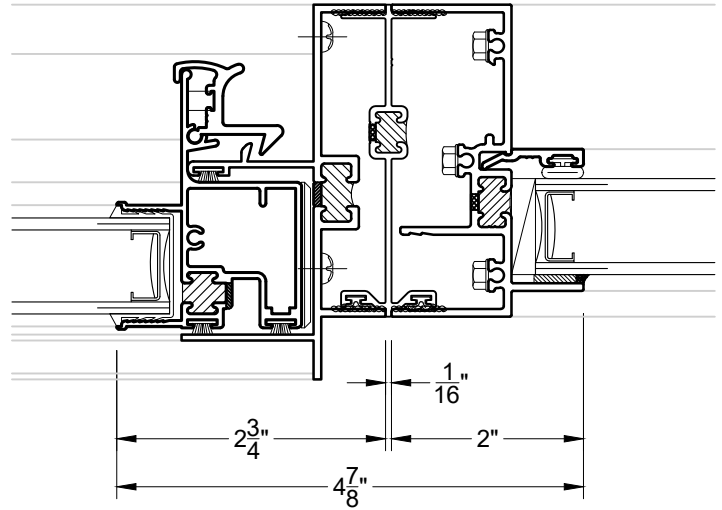

③ SHORT LEG H MULLION
 SL5600 & PW5100

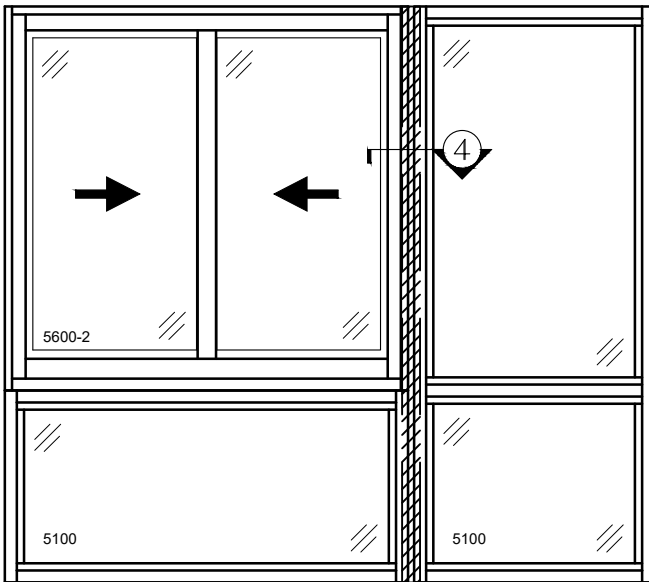

SL5600 OVER PW5100 & PW5100-2V
 W/ 3PC MULLION

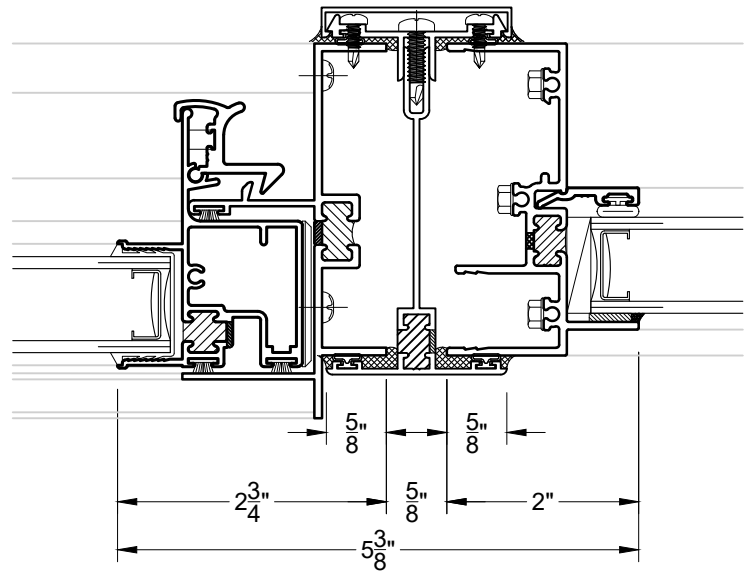

④ 3PC MULLION
 SL5600 & PW5100

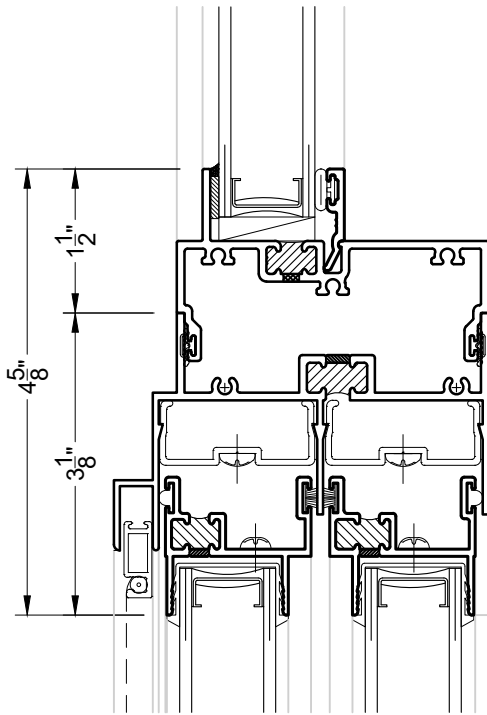

⑤ MALE FRAME MULLION
 PW5100 MALE OVER SL5600

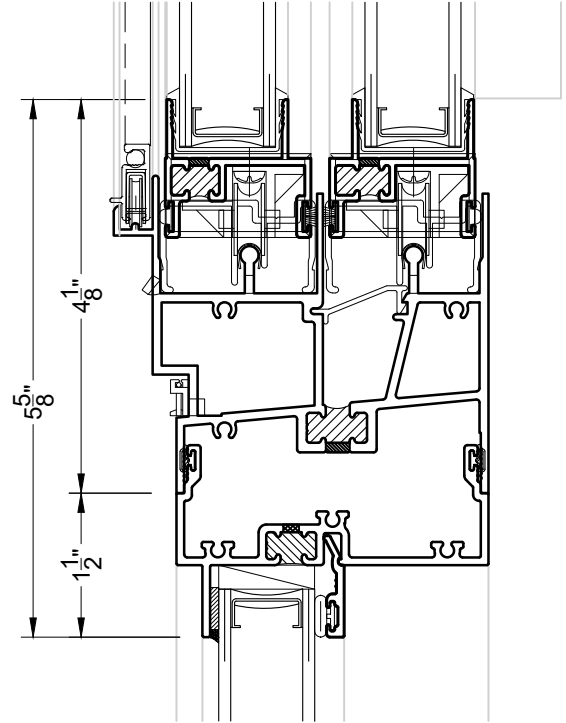

⑥ MALE FRAME MULLION
 SL5600 OVER PW5100 MALE

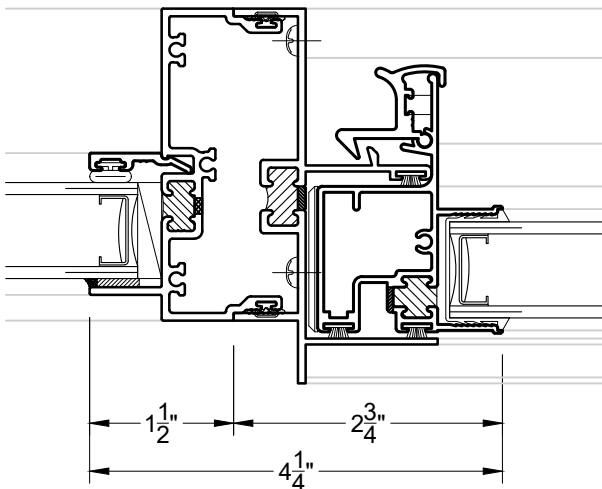

⑦ MALE FRAME MULLION
 PW5100 MALE & SL5600

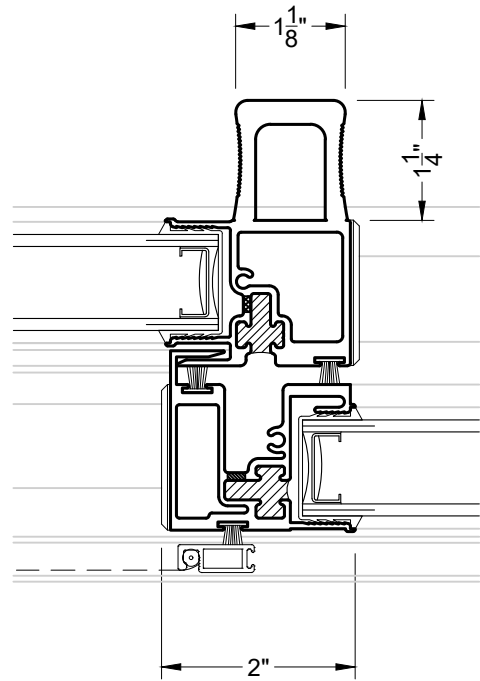

⑧ HEAVY DUTY MEETING RAIL
 SL5600

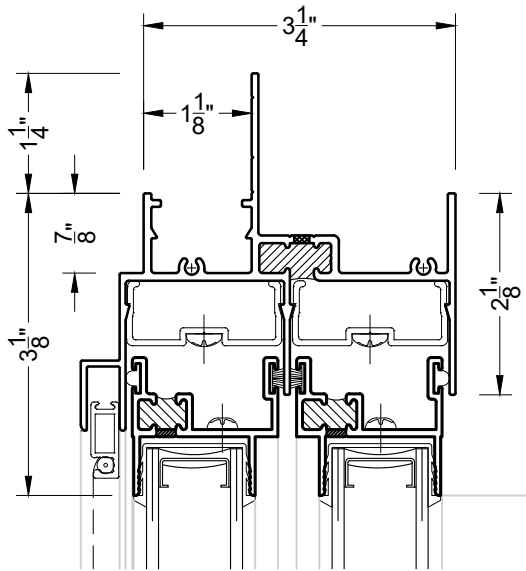

① NAILING FIN HEAD
 SL5600

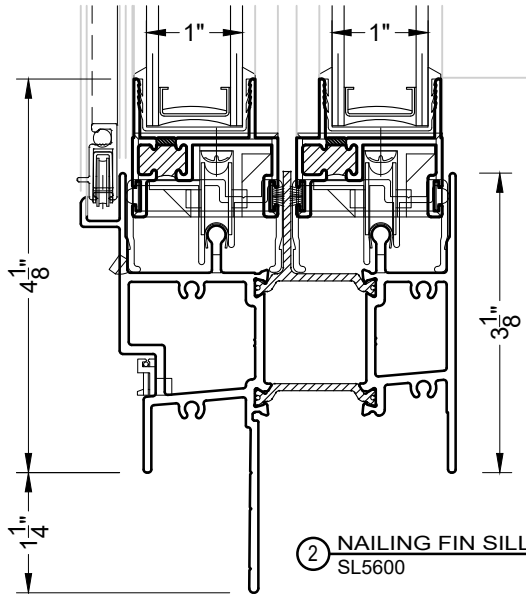

② NAILING FIN SILL
 SL5600

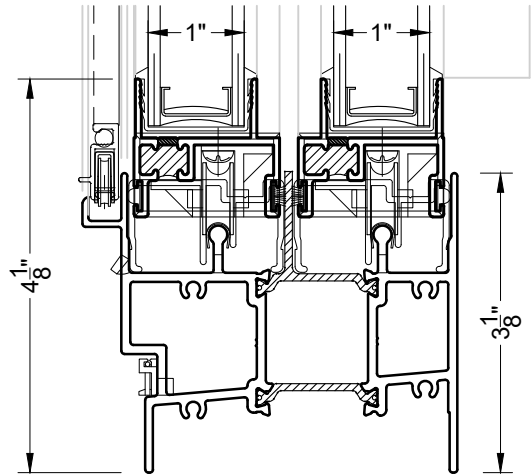

②A EQUAL LEG SILL W/ INSULBAR
 SL5600

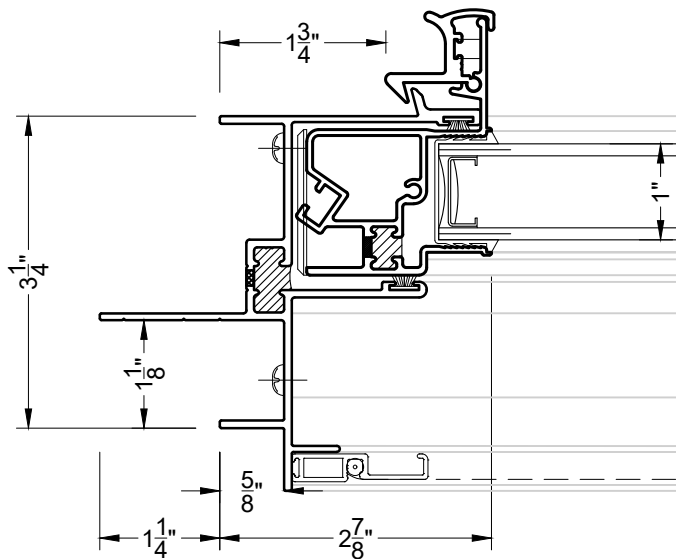

③ NAILING FIN JAMB
 SL5600

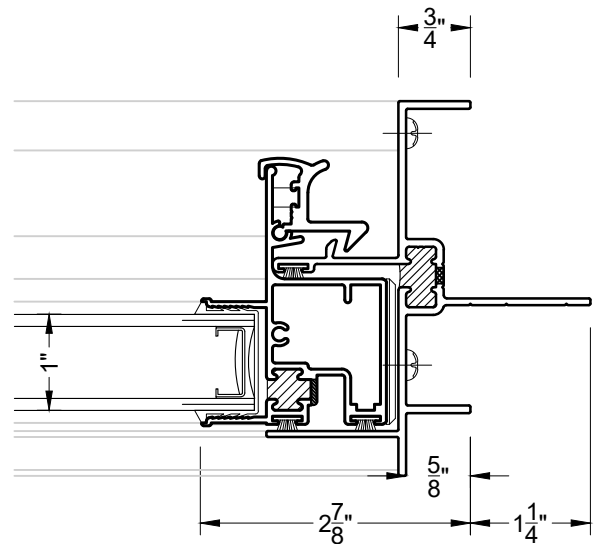

⑤ NAILING FIN JAMB
 SL5600

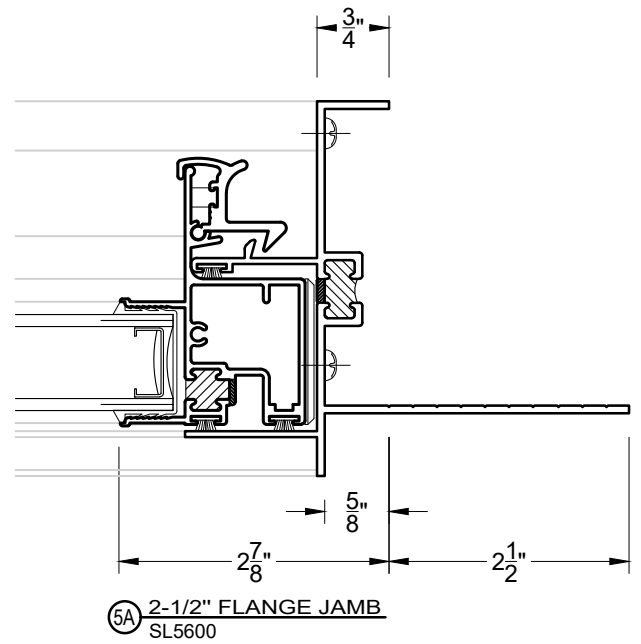
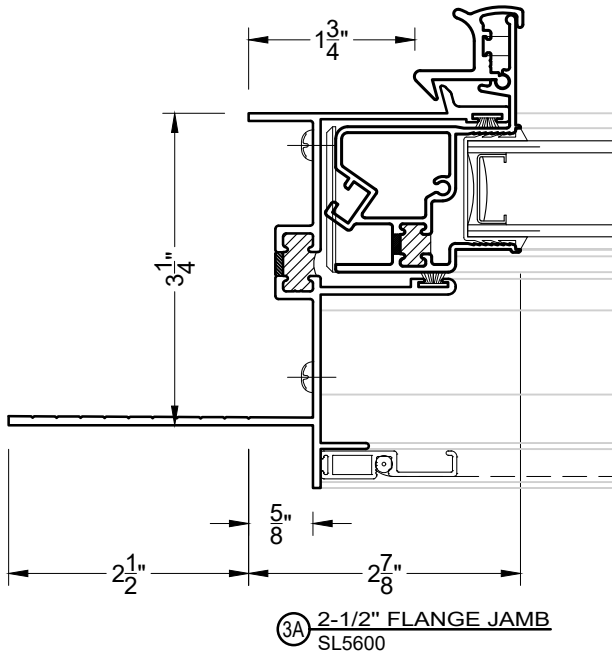
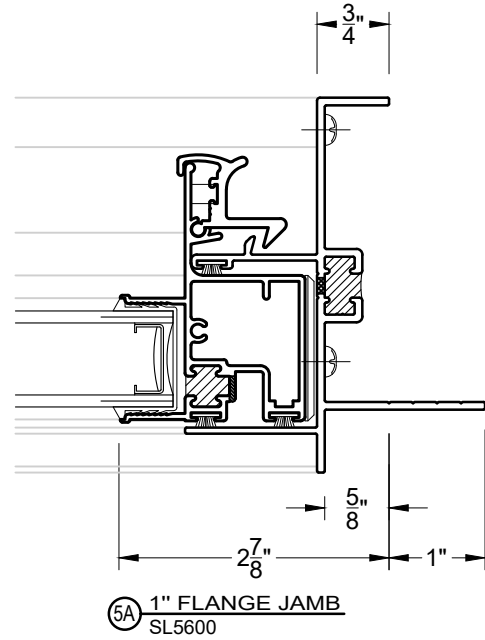
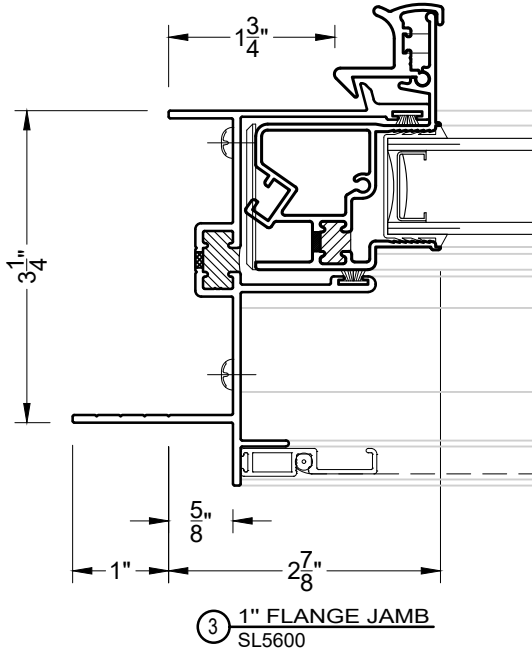

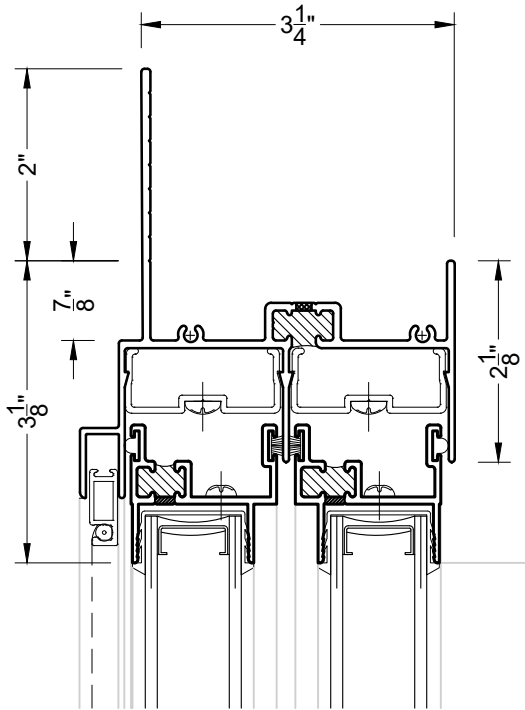

① 2" FLANGE HEAD
 SL5600

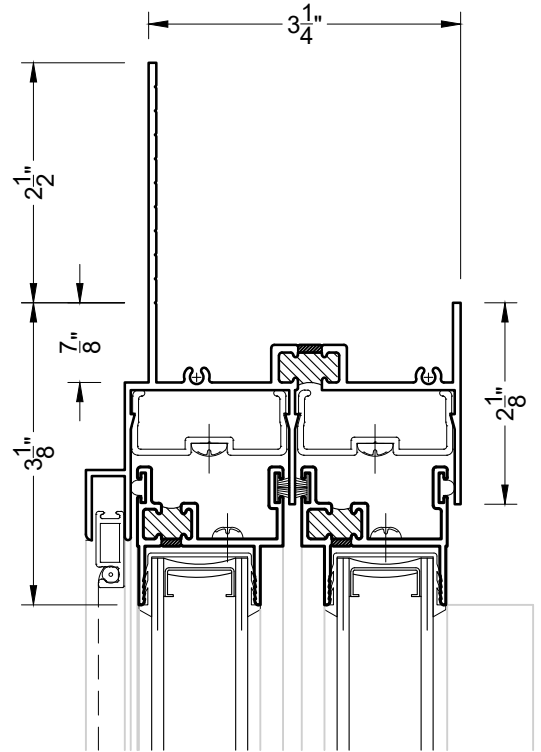

①A 2-1/2" FLANGE HEAD
 SL5600

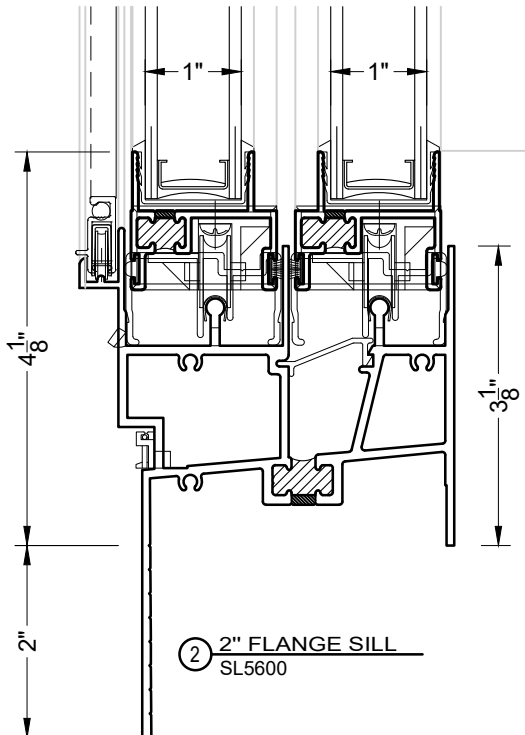

② 2" FLANGE SILL
 SL5600

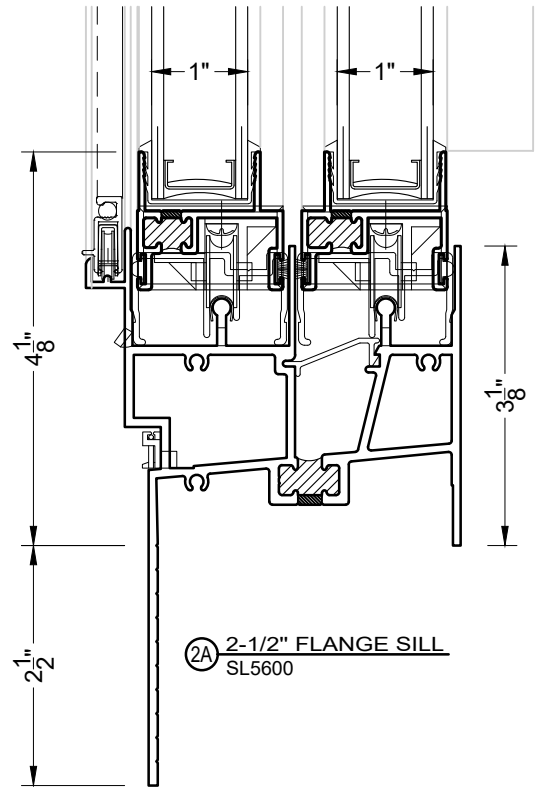

②A 2-1/2" FLANGE SILL
 SL5600

