

SERIES 1240 SLIDING PATIO DOOR

TEST SIZE W x H	AAMA RATING	AIR INFILTRATION	DESIGN PRESSURE	WATER RESISTANCE	U-VALUE	SHGC	VT
95 ¹ / ₄ " x 83"	LC-PG45	<0.30 cfm/ft ²	45 psf	6 psf	0.31-0.57	0.17-0.61	0.28-0.65



TABLE OF CONTENT

- INTRODUCTION -P1
- 2 LITE SLIDING DOOR -P2
- 3 LITE SLIDING DOOR -P3
- MULLION -P4-P5
- SLIDE ON NAILING FIN -P6
- LOW SILL -P6
- FACE FLANGE -P7-P8

FEATURES

- ALUMINUM THERMAL-BREAK SLIDING PATIO DOOR
- 4-1/2" FRAME DEPTH
- FIELD ASSEMBLED PRODUCT
- 1" DOUBLE PANE INSULATED TEMPERED GLASS
- AAMA 2604 POWDER COAT PAINT
- BLACK PAINT LOCKING HANDLE

OPTIONAL SELECTIONS

- LOW-E COATING & ARGON FILLED IGU
- 1-1/2" SLIDE ON NAILING FIN
- 2" SCREW ON FLANGE
- 3" SLIDE ON FACE FLANGE
- CUSTOM FINISH AND CUSTOM COLOR
- GRIDS
- HANDLE WITH KEY LOCK AND DIFFERENT COLOR
- STAINLESS STEEL ROLLERS UPGRADE ON PANEL AND/ OR SCREEN DOOR
- LOW THRESHOLD SILL
- FULLY REVERSIBLE FOR 2-LITE SLIDING DOOR
- FIBERMESH LOCKING SCREEN
- OTHER OPTIONAL ACCESSORIES

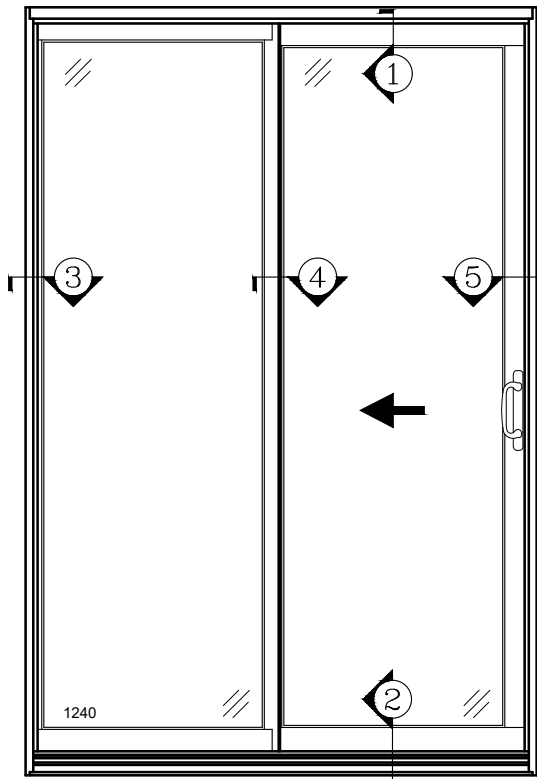

1240 2-LITE SLIDING DOOR (O-X)

FOR 32" CLEAR PATH,
 MIN. REQUIRED 74¹/₄" DOOR WIDTH
 (CLEAR PATH = DOOR WIDTH / 2 - 5¹/₈")

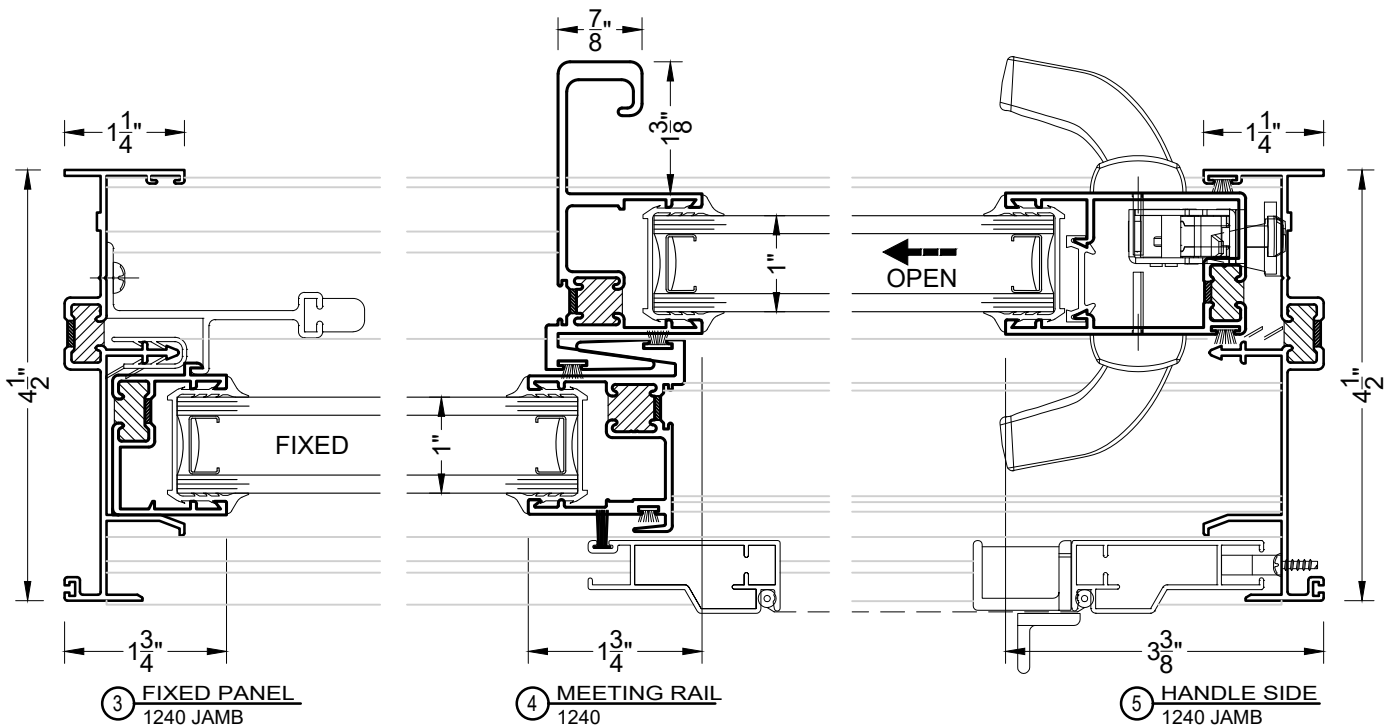
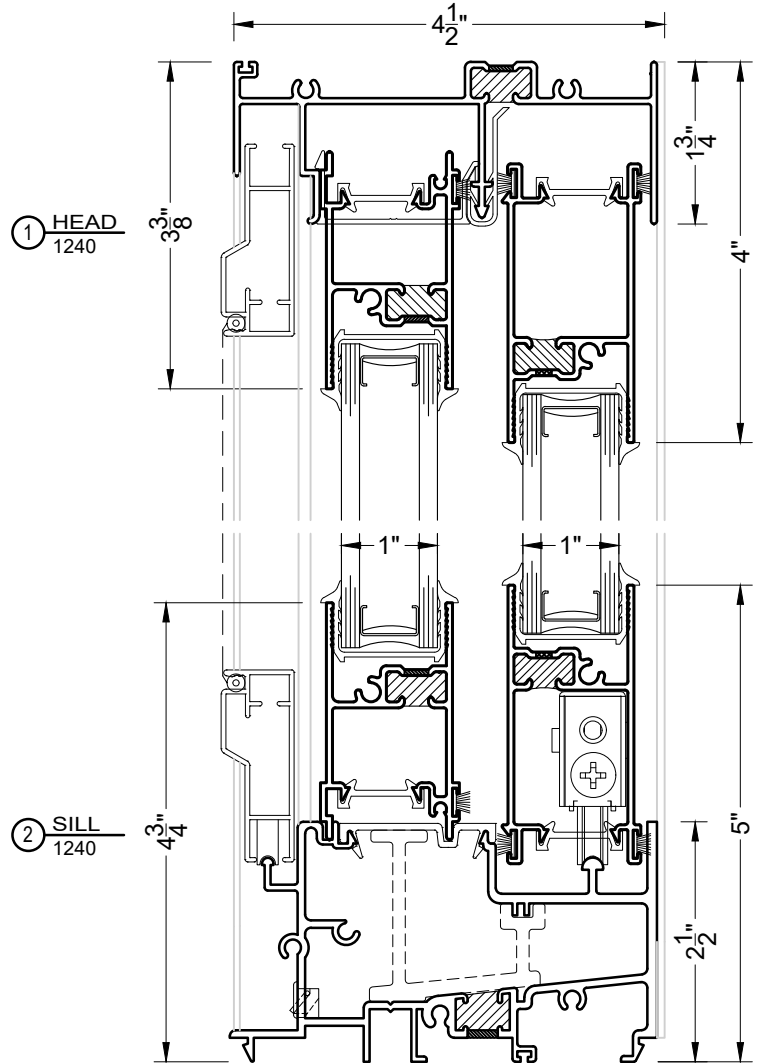

VER: 2020.03

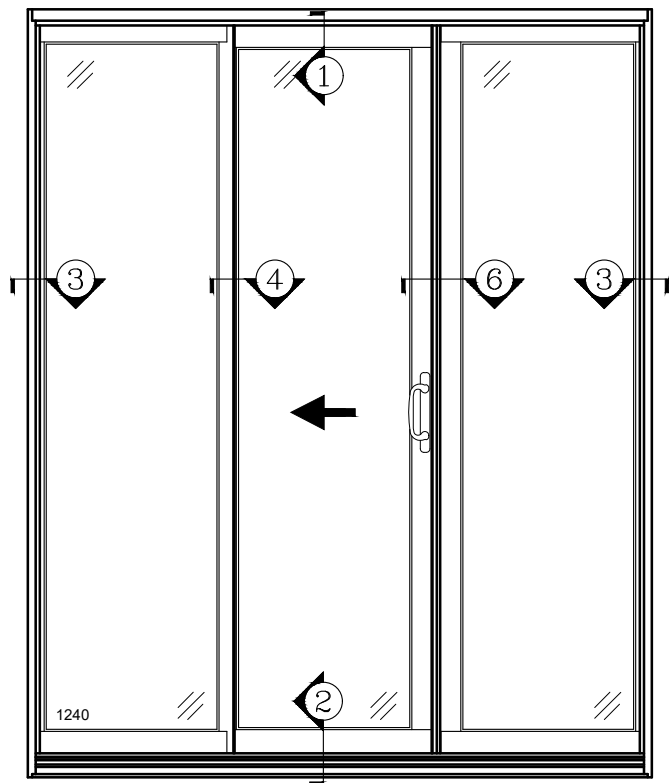

1240 3-LITE SLIDING DOOR (O-X-O)

FOR 32" CLEAR PATH,
 MIN. REQUIRED 112" DOOR WIDTH
 (CLEAR PATH = DOOR WIDTH / 3 - 5¹/₄")

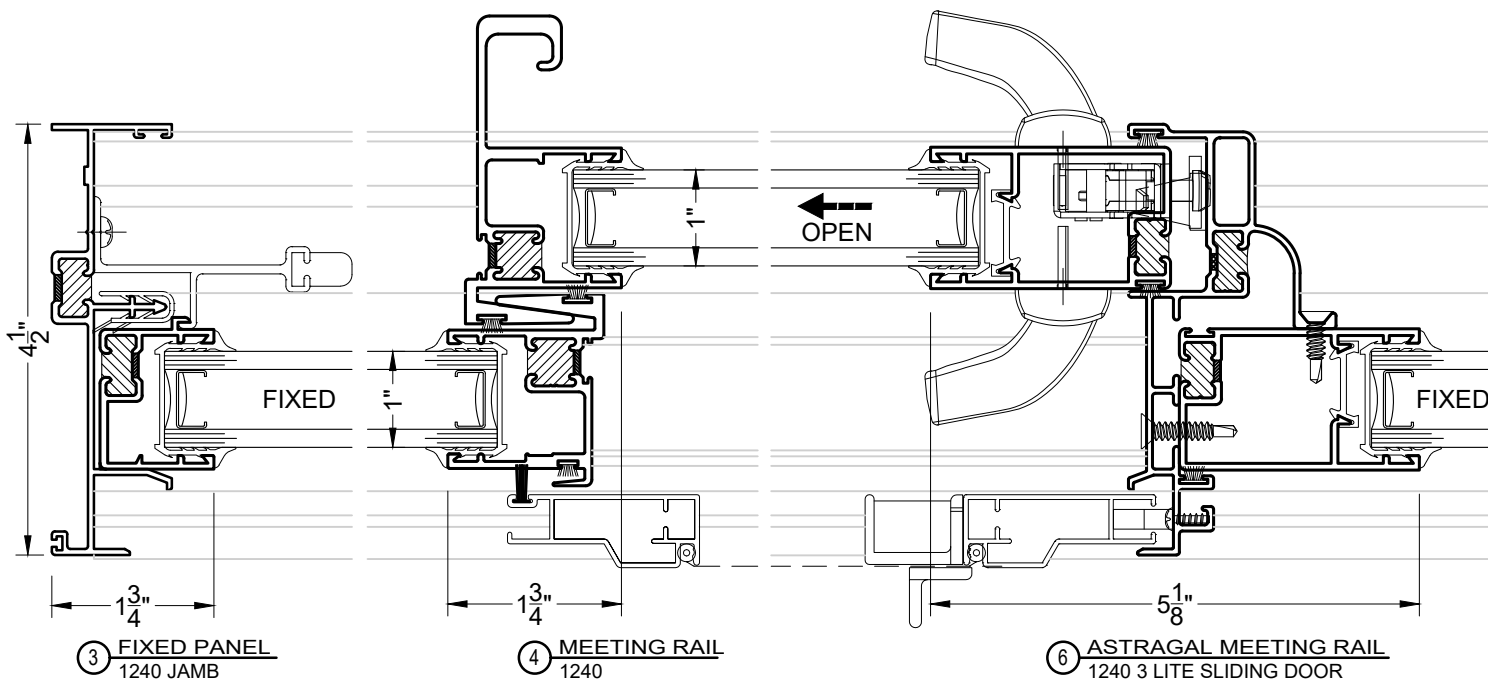

③ FIXED PANEL
1240 JAMB

④ MEETING RAIL
1240

⑥ ASTRAGAL MEETING RAIL
1240 3 LITE SLIDING DOOR

VER: 2020.03

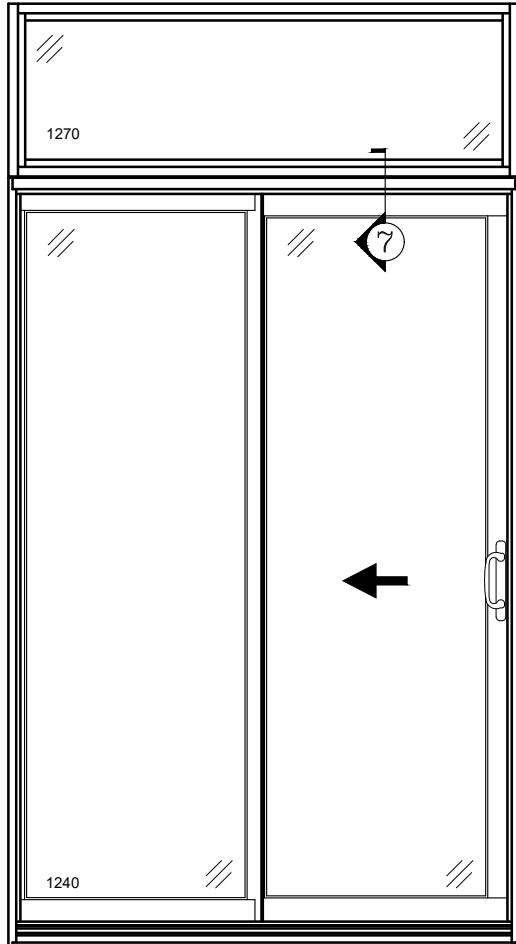

1270A TRANSOM OVER 1240

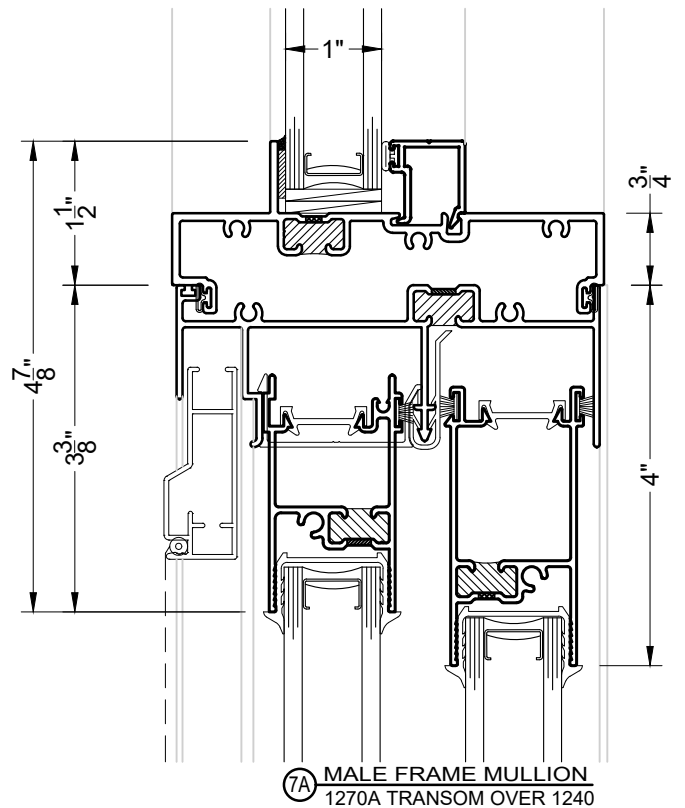
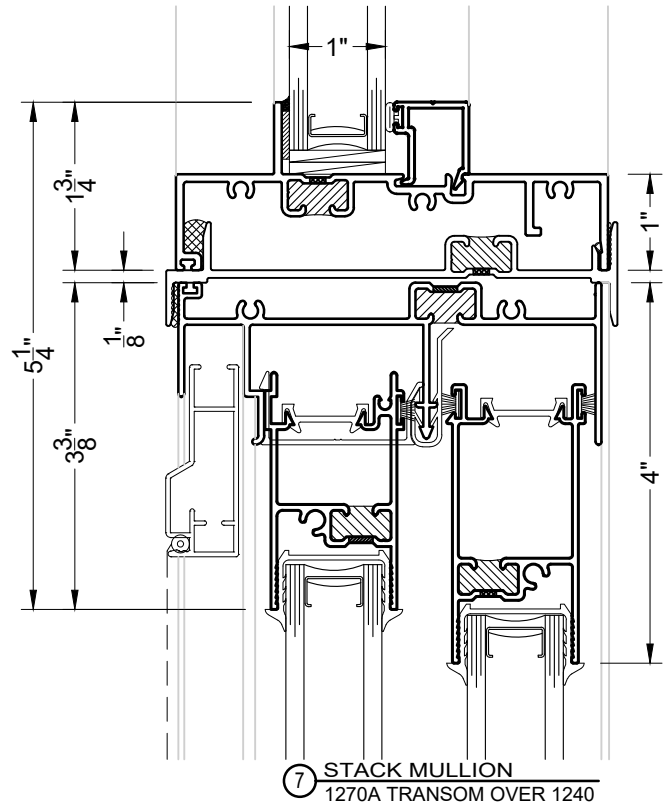

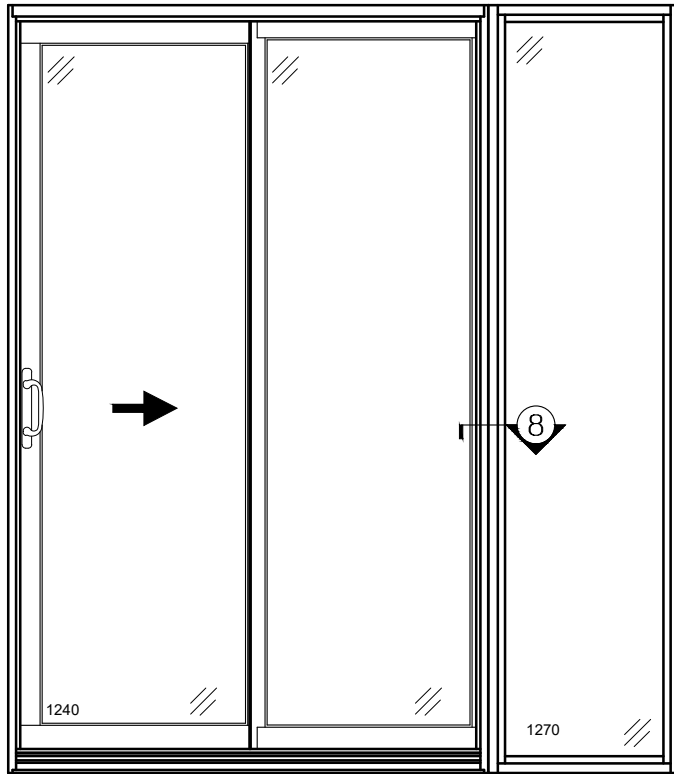

1240 W/ 1270A SIDELITE

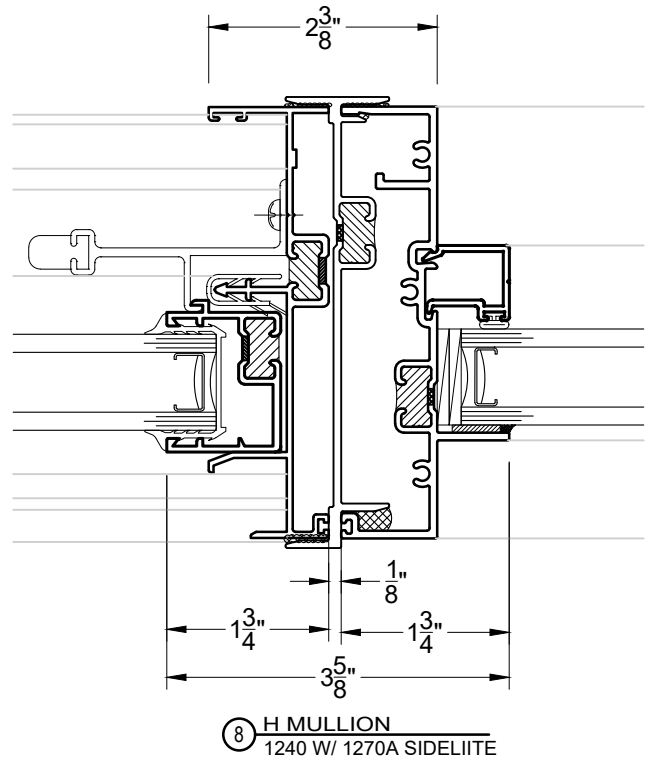

8 H MULLION
 1240 W/ 1270A SIDELITE

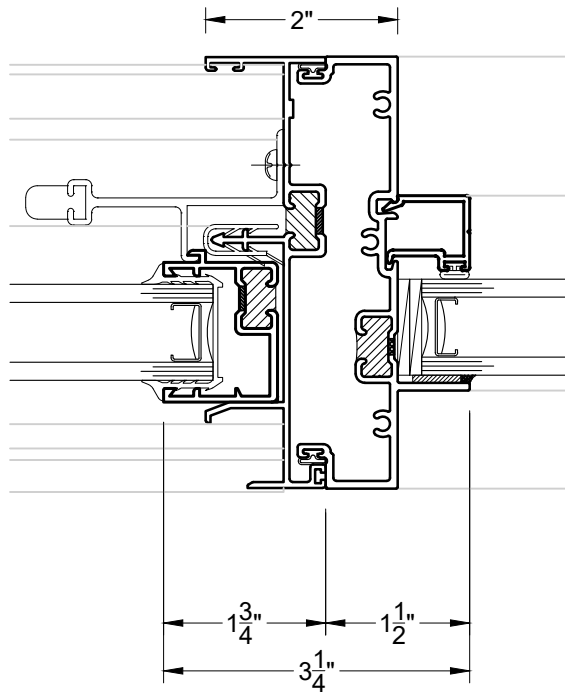

8A MALE FRAME MULLION
 1240 W/ 1270A SIDELITE

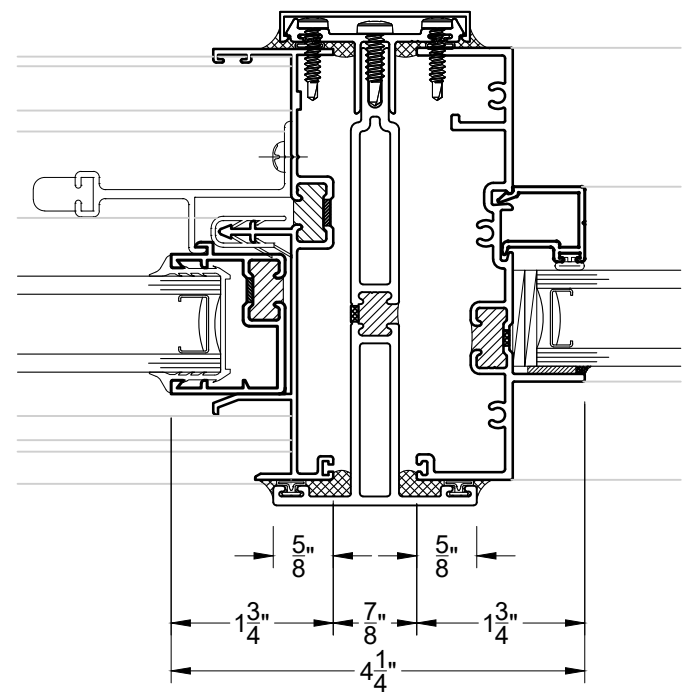

8B 3PC MULLION
 1240 W/ 1270A SIDELITE

VER: 2020.03

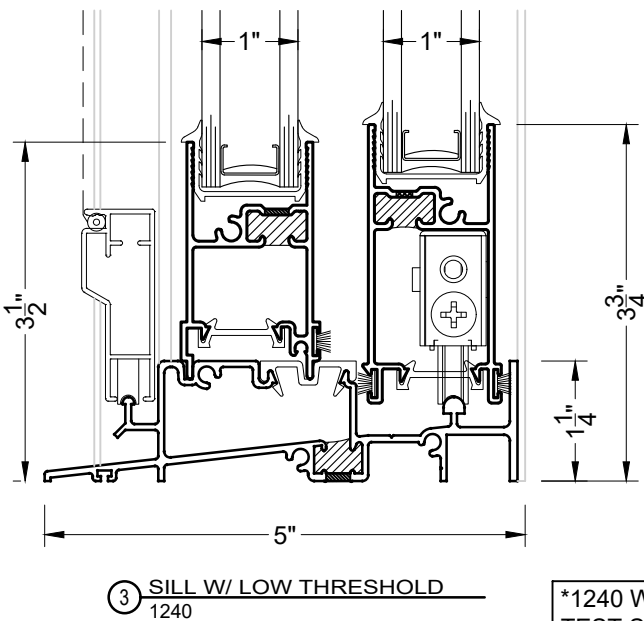
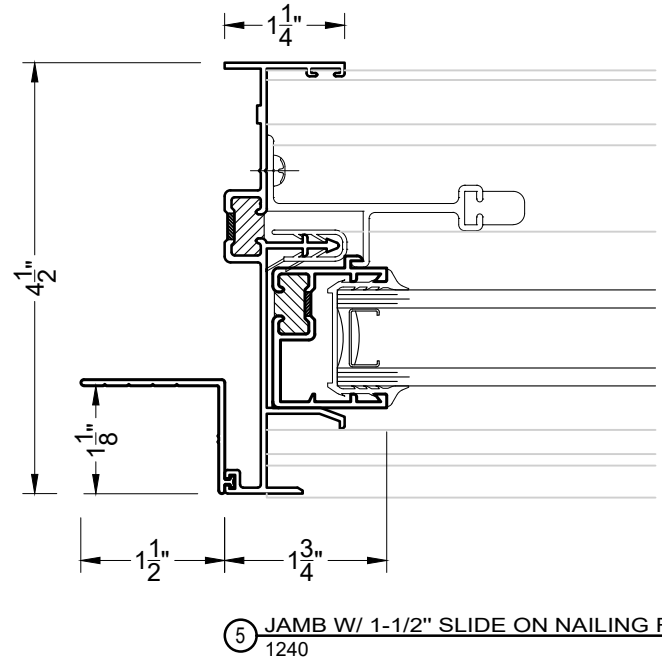
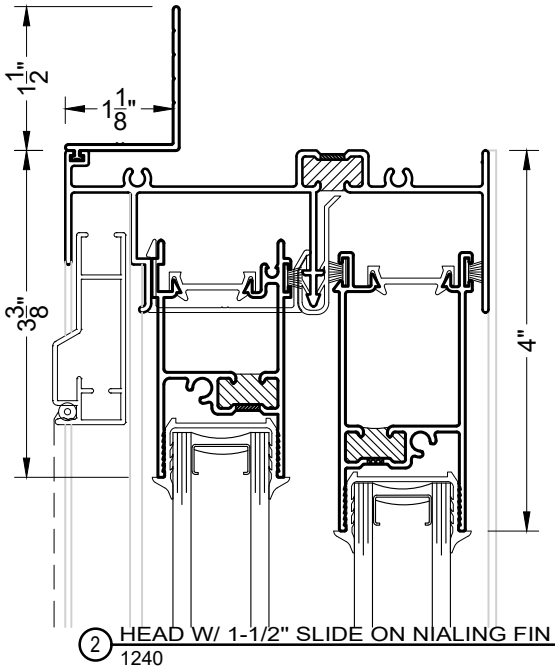

*1240 WITH LOW SILL
 TEST SIZE: 87"X83"
 CLASS LC-PG25
 3.76PSF WATER PENETRATION RESISTANCE

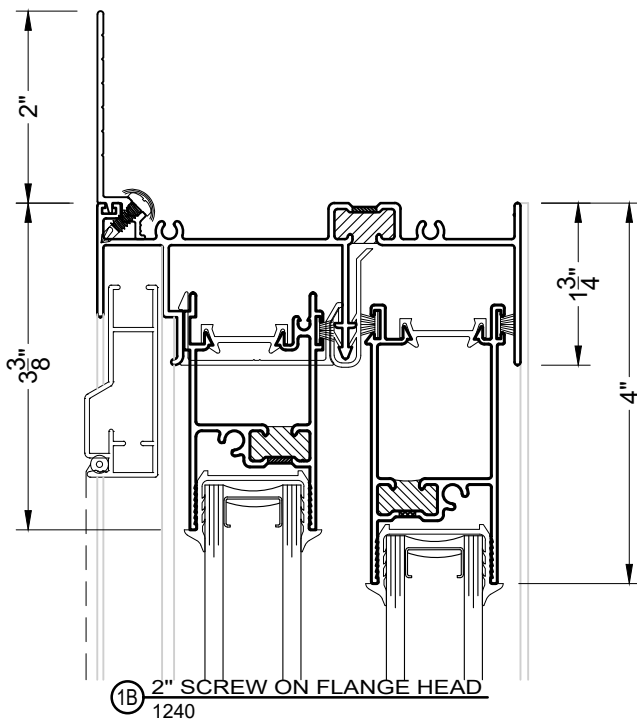
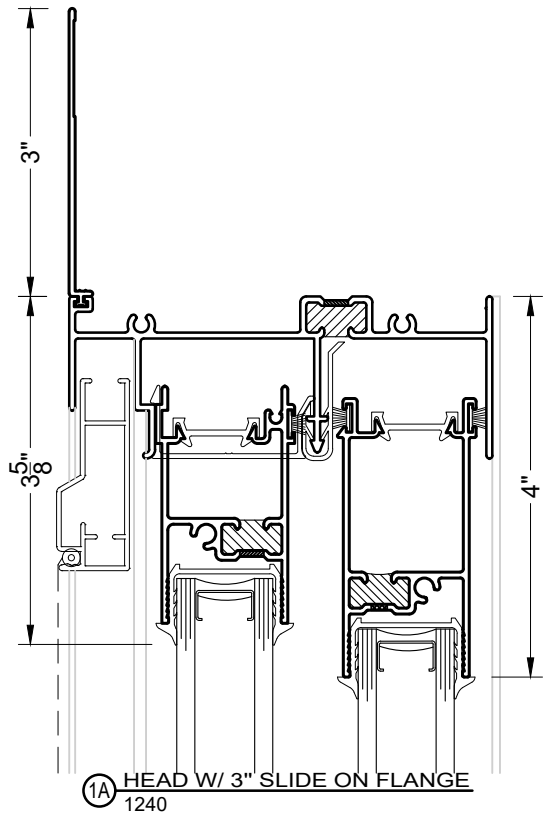
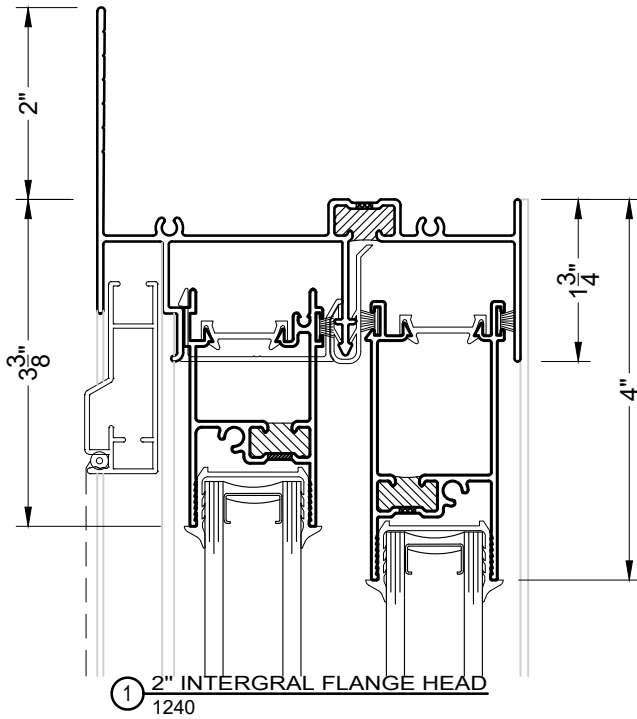

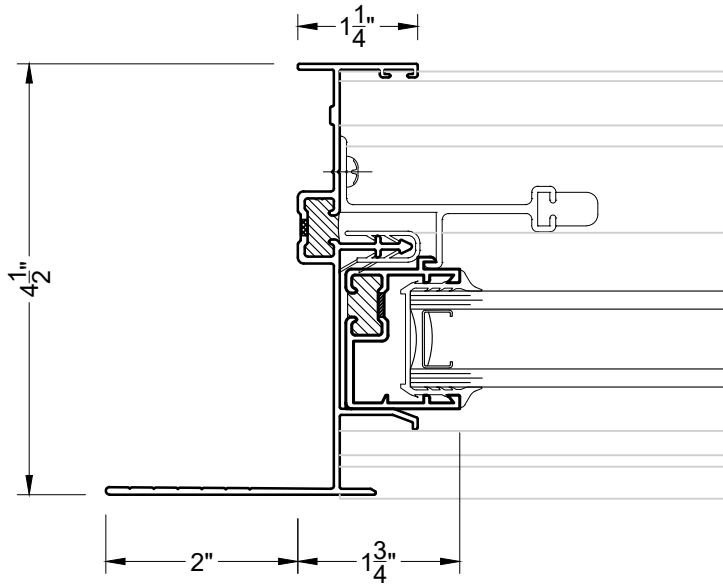

④ 2" INTEGRAL FLANGE JAMB
1240

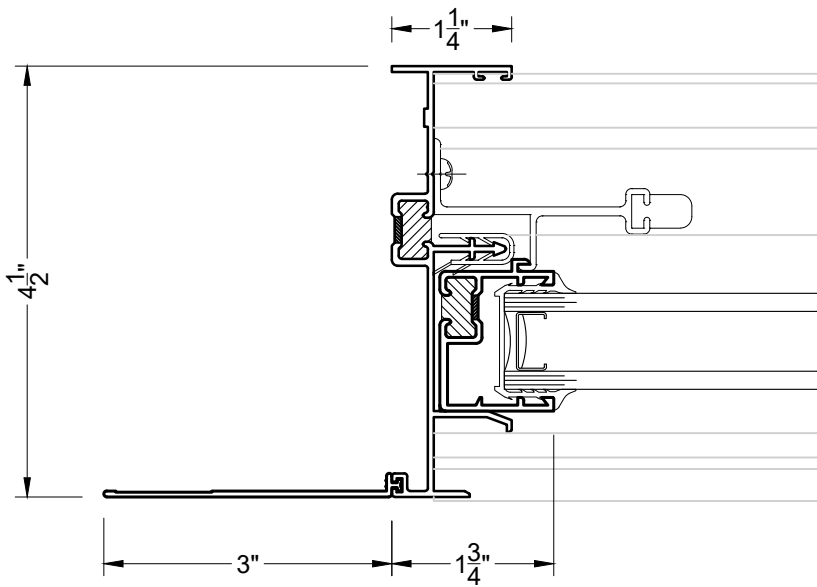

④A JAMB W/ 3" SLIDE ON FLANGE
1240

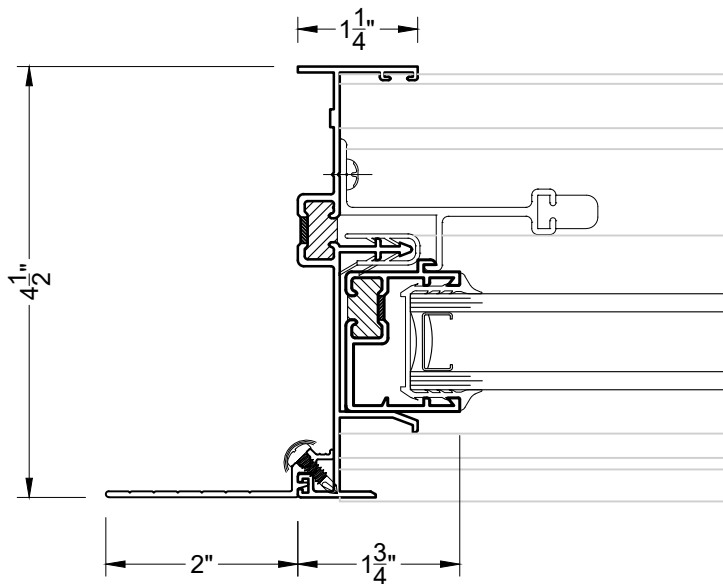

④ 2" SCREW ON FLANGE JAMB
1240

VER: 2020.03