

SERIES 1450 TERRACE OUT-SWING DOOR

OPTION	TEST SIZE W x H	AAMA RATING	AIR INFILTRATION	DESIGN PRESSURE	WATER RESISTANCE	U-VALUE	SHGC	VT
STANDARD	48" x 96"	AW-PG75	≤0.10 cfm/ft ²	75 psf	12 psf	0.31-0.54	0.15-0.5	0.2-0.53
ADA SILL	48" x 96"	AW-PG50	≤0.20 cfm/ft ²	50 psf	10 psf			

TABLE OF CONTENT

- INTRODUCTION -P1
- 1450 -P2
- 1450-1 -P3
- 1450-2 -P4
- MULLION -P5-P7
- FACE FLANGE -P8
- 1450 ADA OPTIONS -P9-P12
- HANDLE & LOCK OPTIONS -P13-P14

FEATURES

- ALUMINUM THERMAL-BREAK TERRACE OUT-SWING DOOR
- 3-1/4" FRAME DEPTH
- 1" DOUBLE PANE INSULATED TEMPERED GLASS
- HEAVY DUTY EXTRUSION
- AAMA 2604 POWDER COAT PAINT
- OPENING LIMIT BAR
- MULTI POINT LOCK SYSTEM
- THUMB TURN INTERIOR LOCKING MECHANISM

OPTIONAL SELECTIONS

- LOW-E COATING & ARGON FILLED IGU
- 2" FACE FLANGE
- CUSTOM FINISH AND CUSTOM COLOR
- GRIDS
- 1-1/4" INSULATED GLASS
- KEY LOCK ON EXTERIOR
- ADA THRESHOLD
- KICK PLATE
- HYDRAULIC DOOR CLOSER
- MINIMALIST HANDLE DESIGN
- DUMMY HANDLE ON INACTIVE PANEL (1450-2)

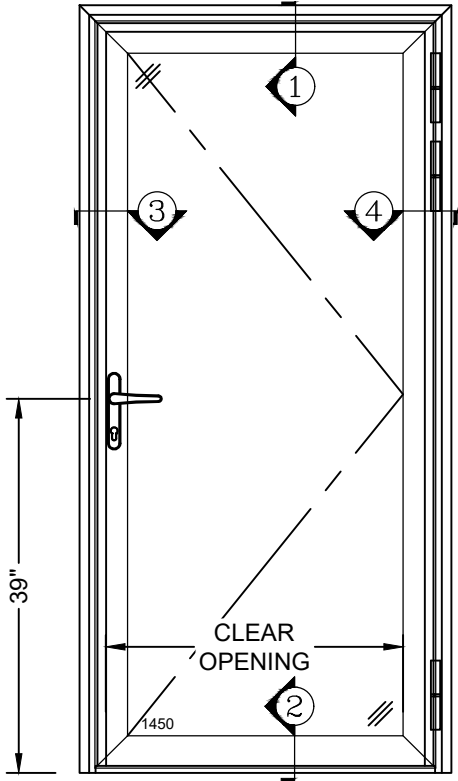

1450 OUT-SWING DOOR

(CLEAR OPENING = DOOR WIDTH - 8")

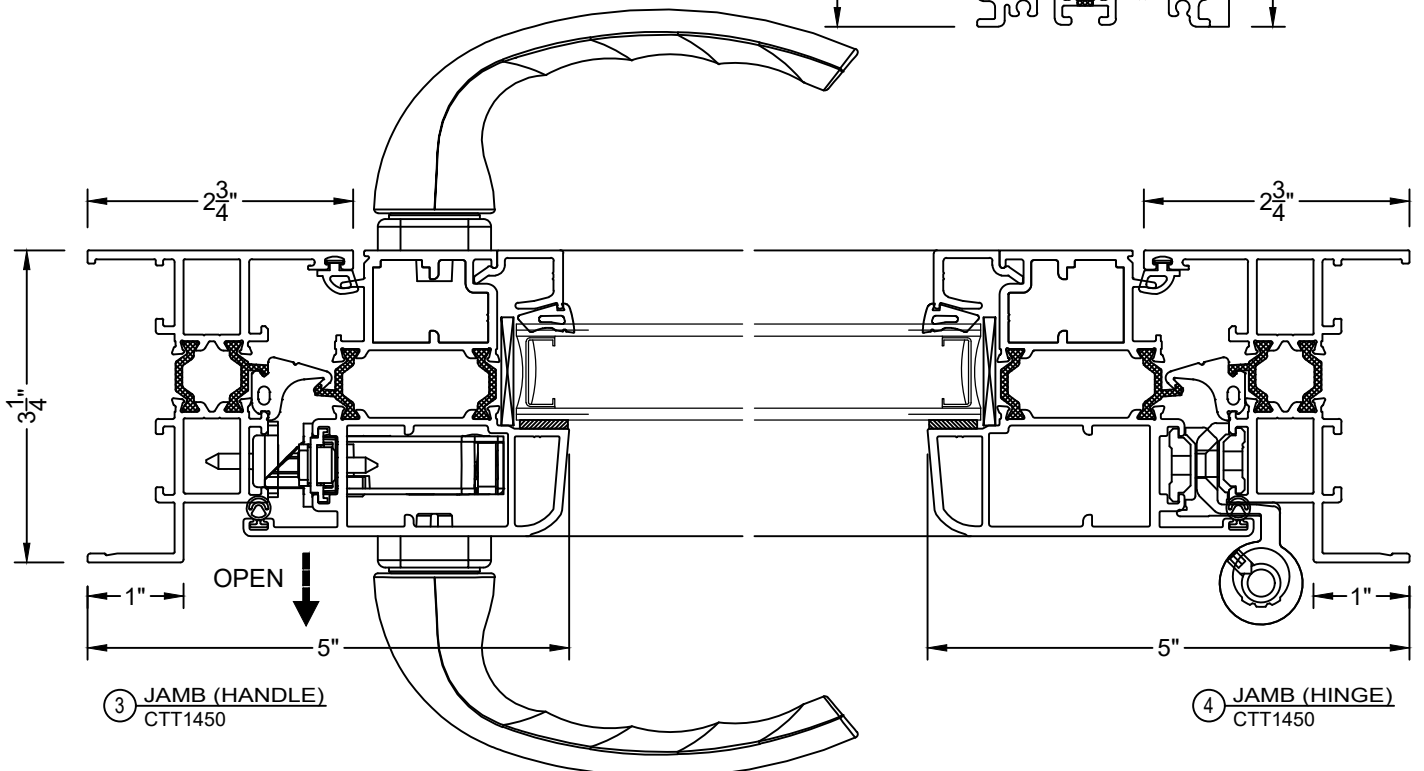
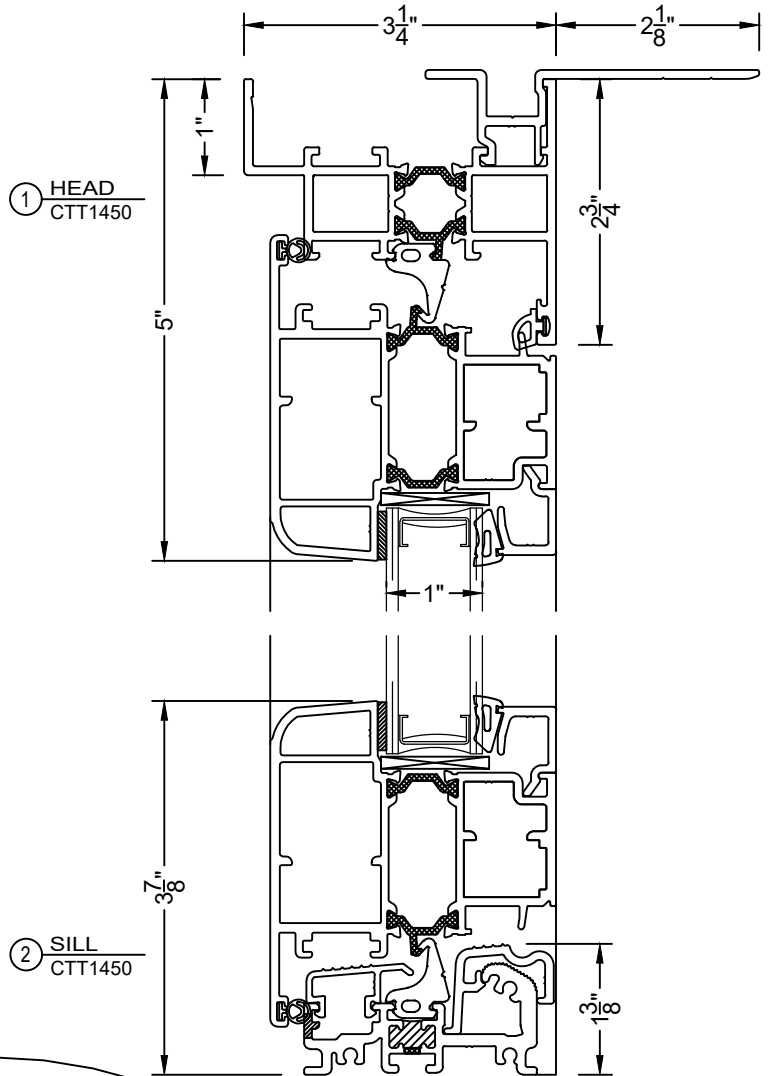

VER: 2025.02

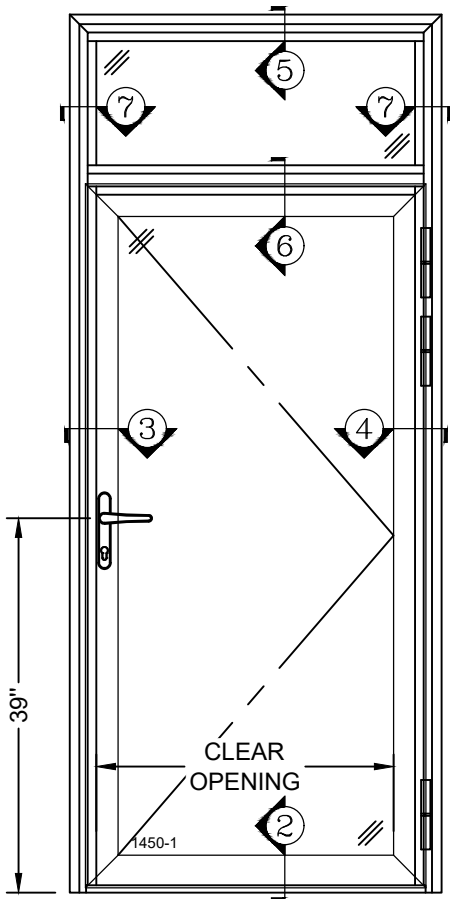

1450-1 OUT-SWING DOOR
W/ TRANSOM

(CLEAR OPENING = DOOR WIDTH - 8")

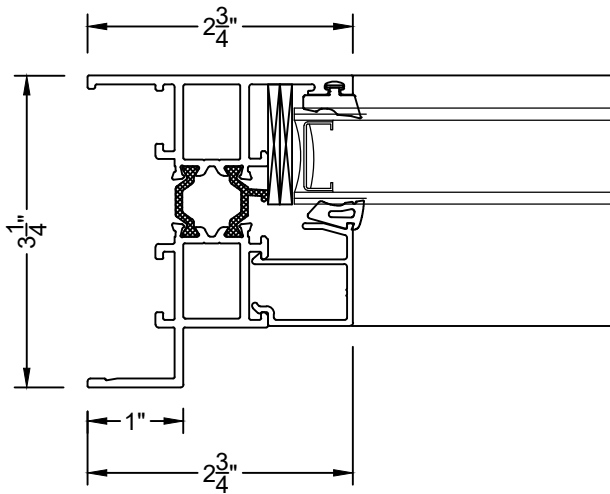
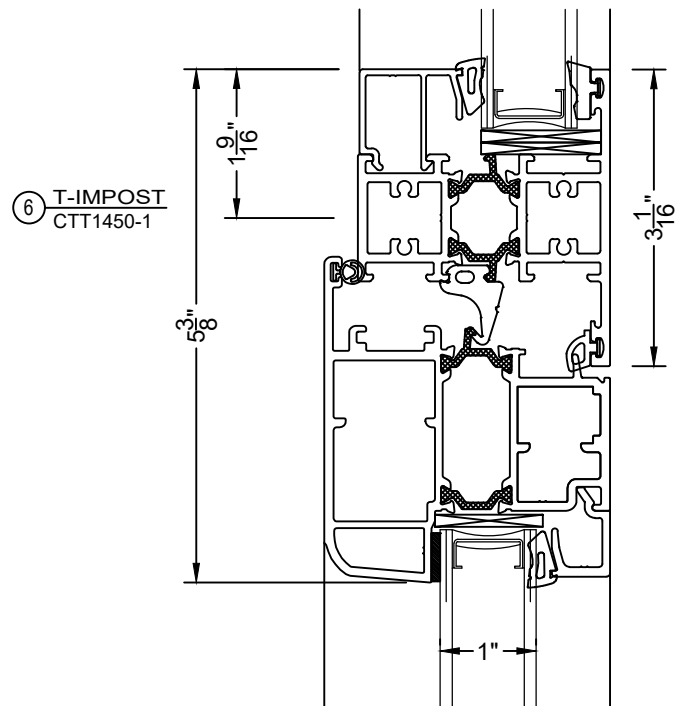
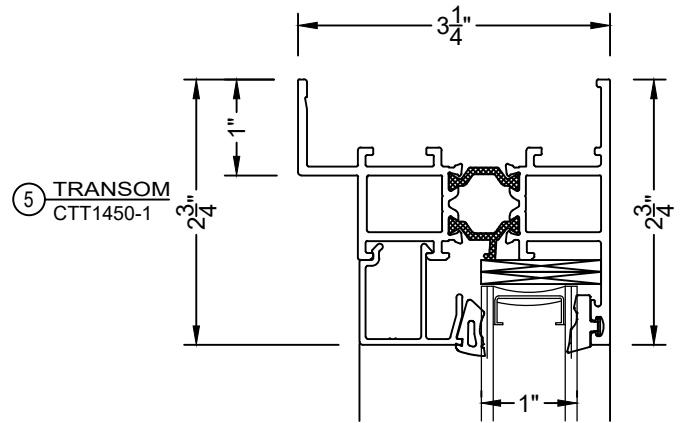

⑦ JAMB (TRANSOM)
CTT1450-1

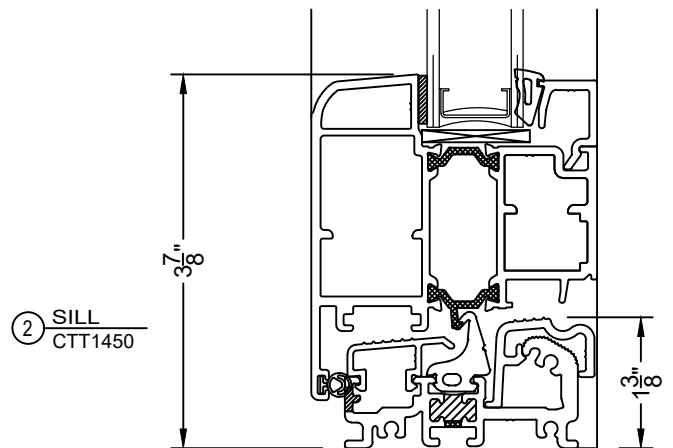

VER: 2025.02

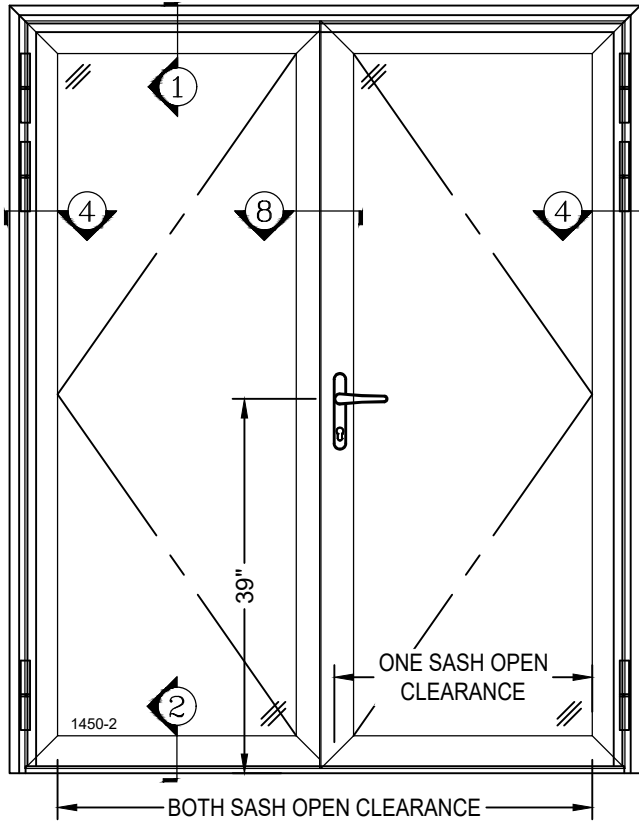

ADA SILL OR INTEGRAL TRANSOM IS NOT AVAILABLE FOR 1450-2 OUT-SWING FRENCH DOOR

1450-2 OUT-SWING FRENCH DOOR*

ONE SASH OPEN:
(CLEAR OPENING = DOOR WIDTH / 2 - 6")

BOTH SASH OPEN:
(CLEAR OPENING = DOOR WIDTH - 10")

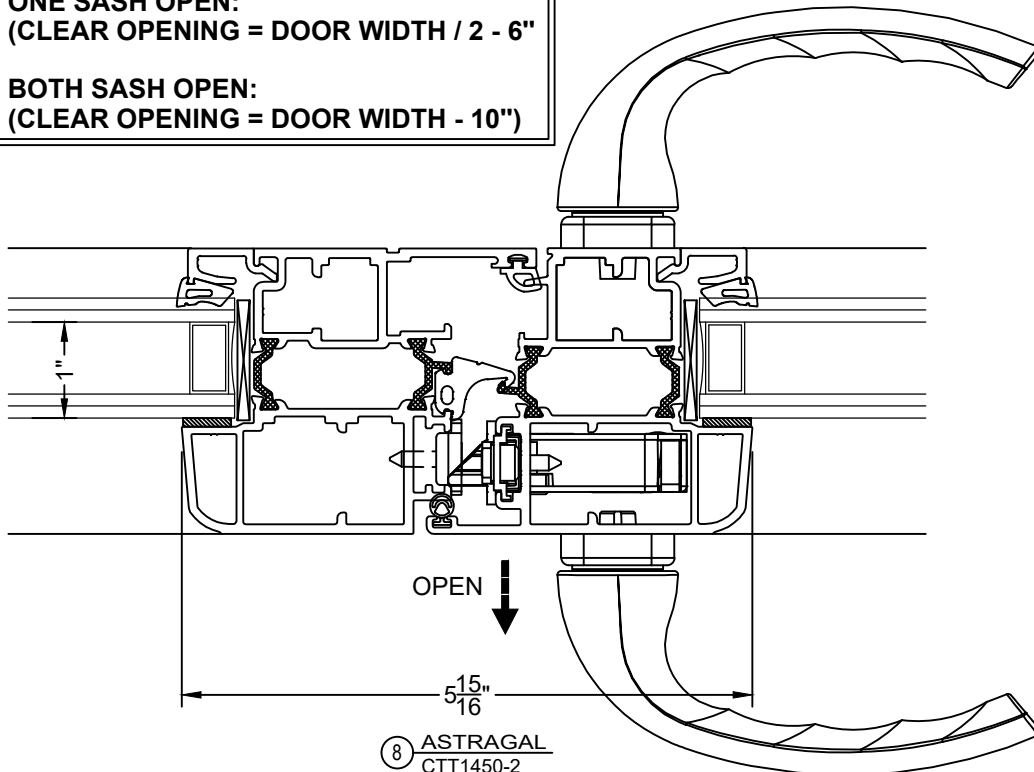

VER: 2025.02

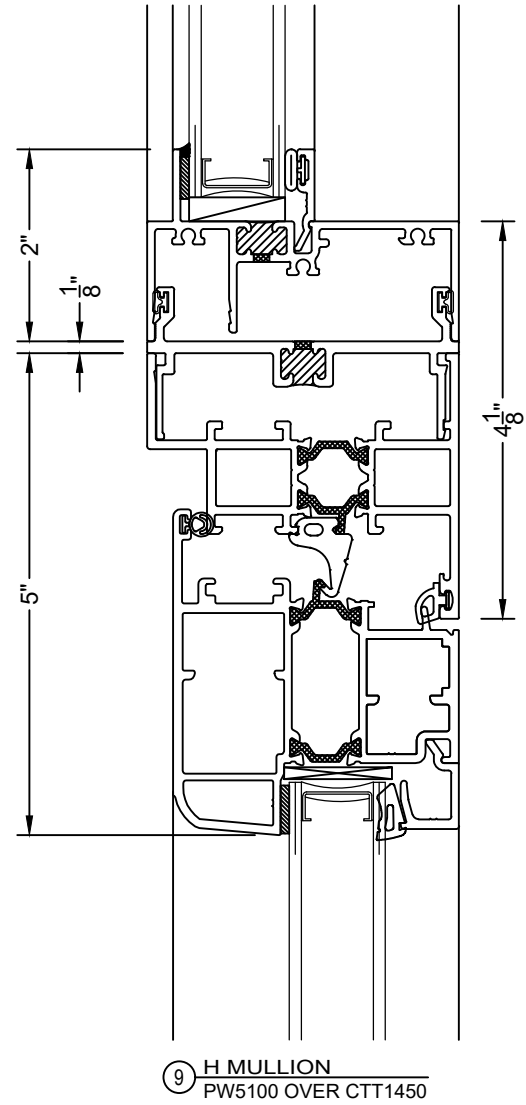
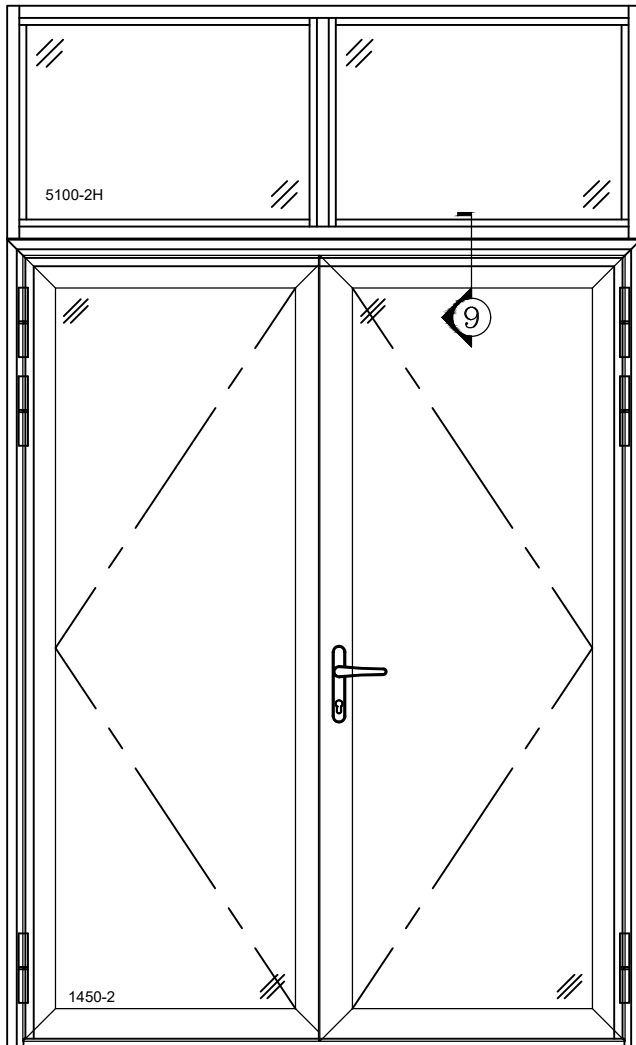

PW5100-2H TRANSOM OVER CTT1450-2
W/ H MULLION

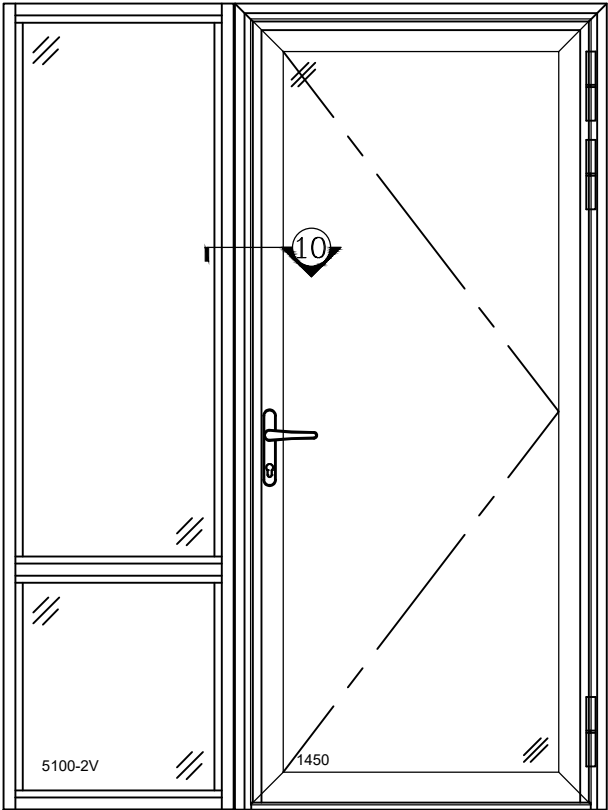

PW5100-2V SIDELITE & CTT1450
W/ H MULLION

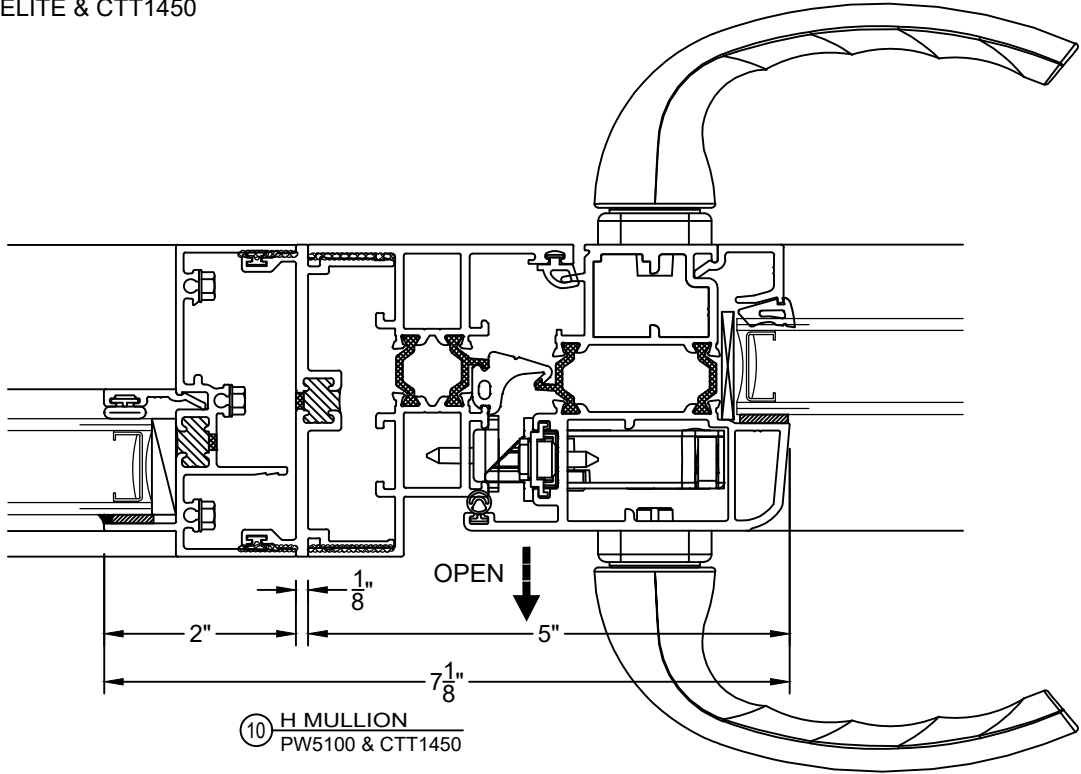

VER: 2025.02

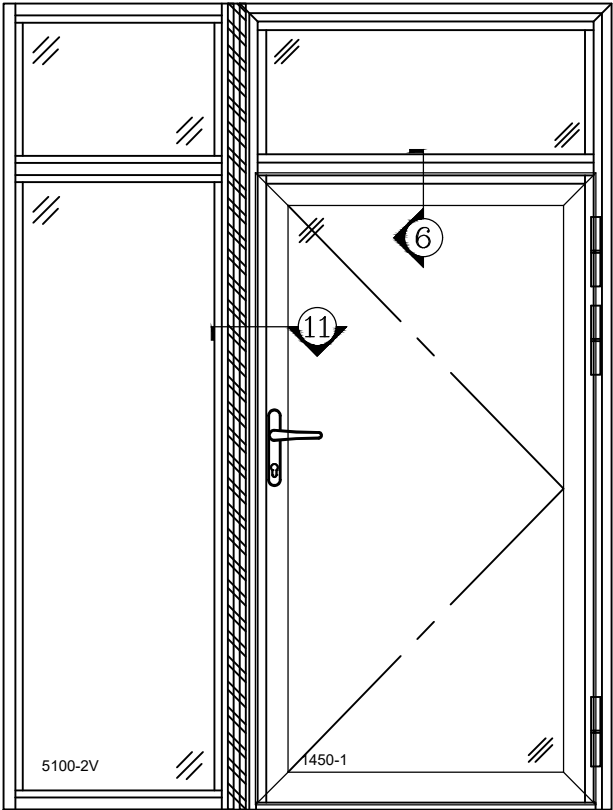

PW5100-2V SIDELITE & CTT1450-1
W/ 3CP MULLION

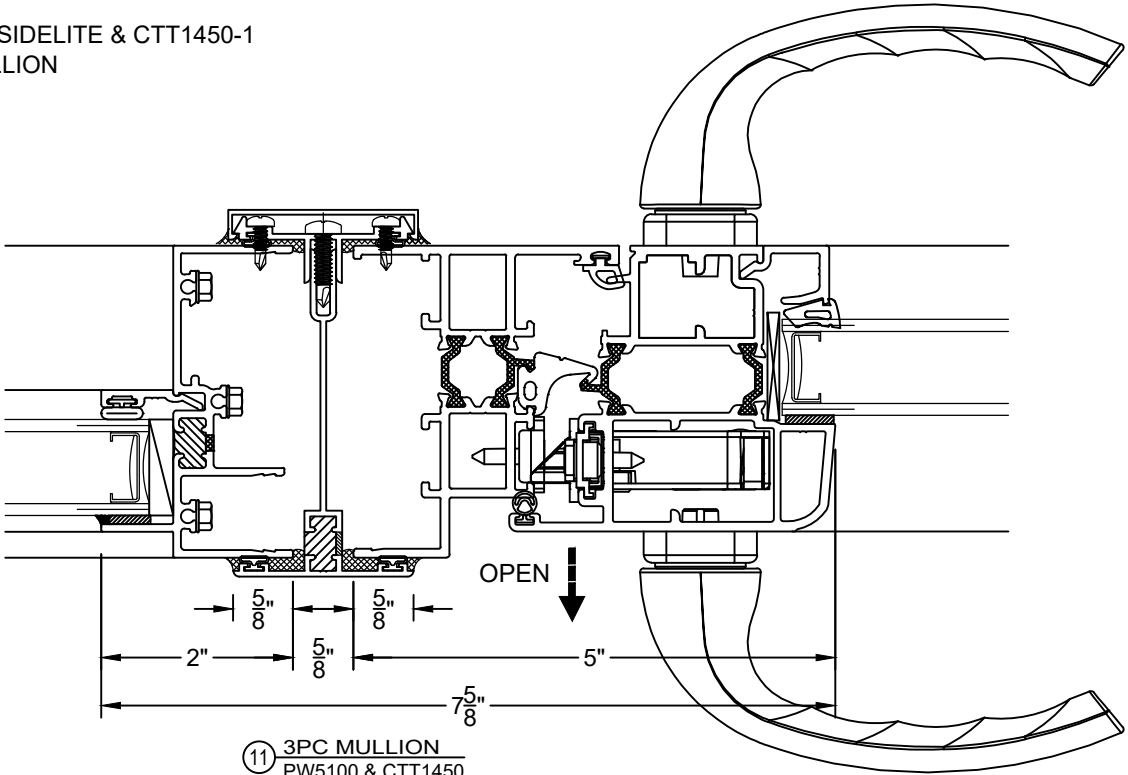

VER: 2025.02

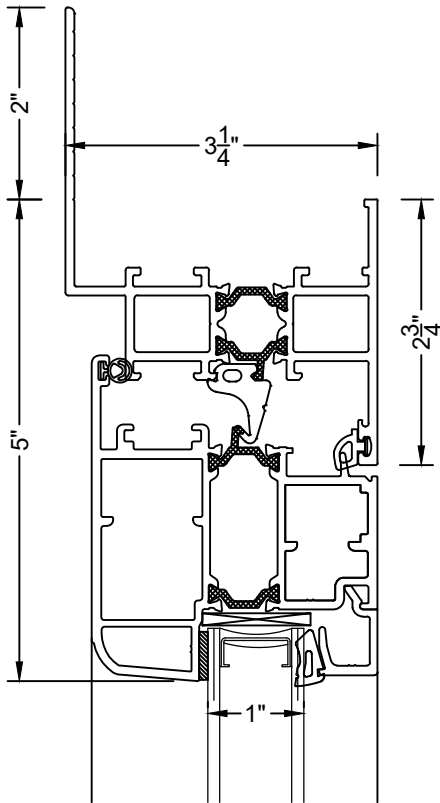

①B 2" FLANGE HEAD
CTT1450

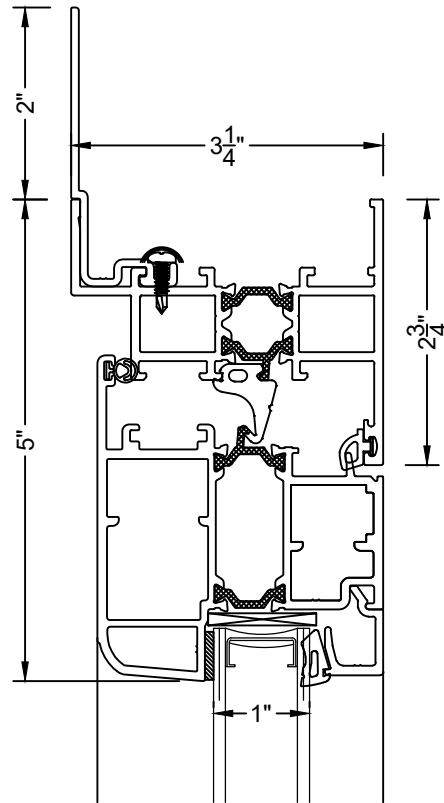

①A 2" APPLIED ON FLANGE HEAD
CTT1450

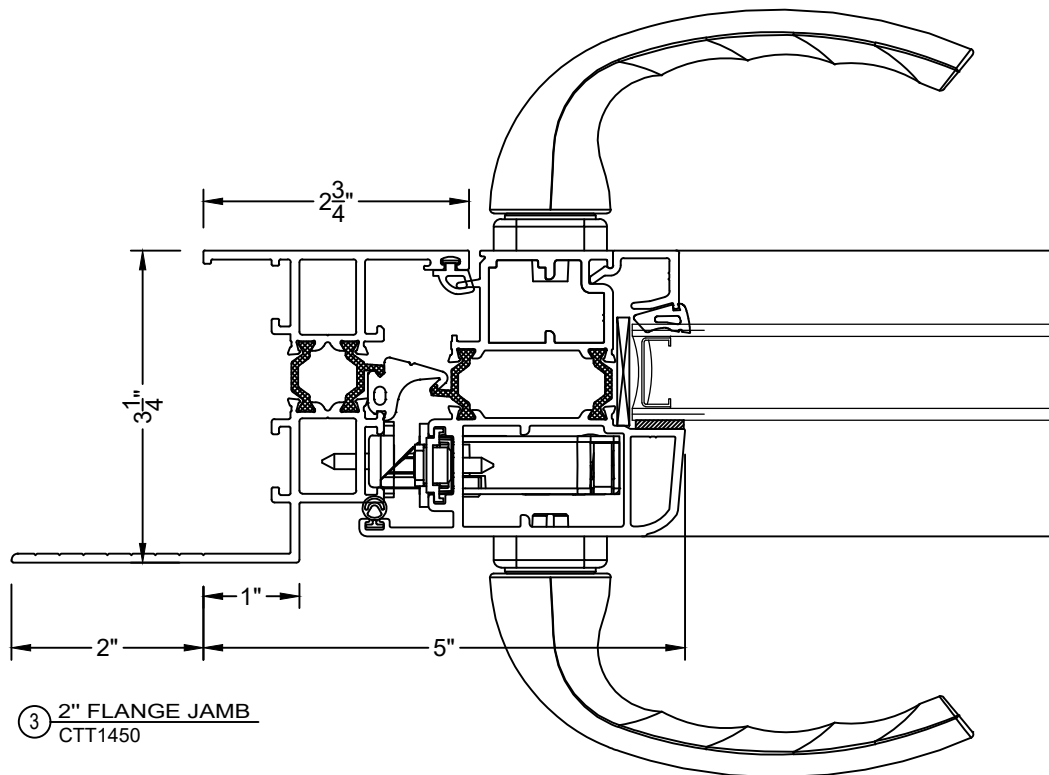

③ 2" FLANGE JAMB
CTT1450

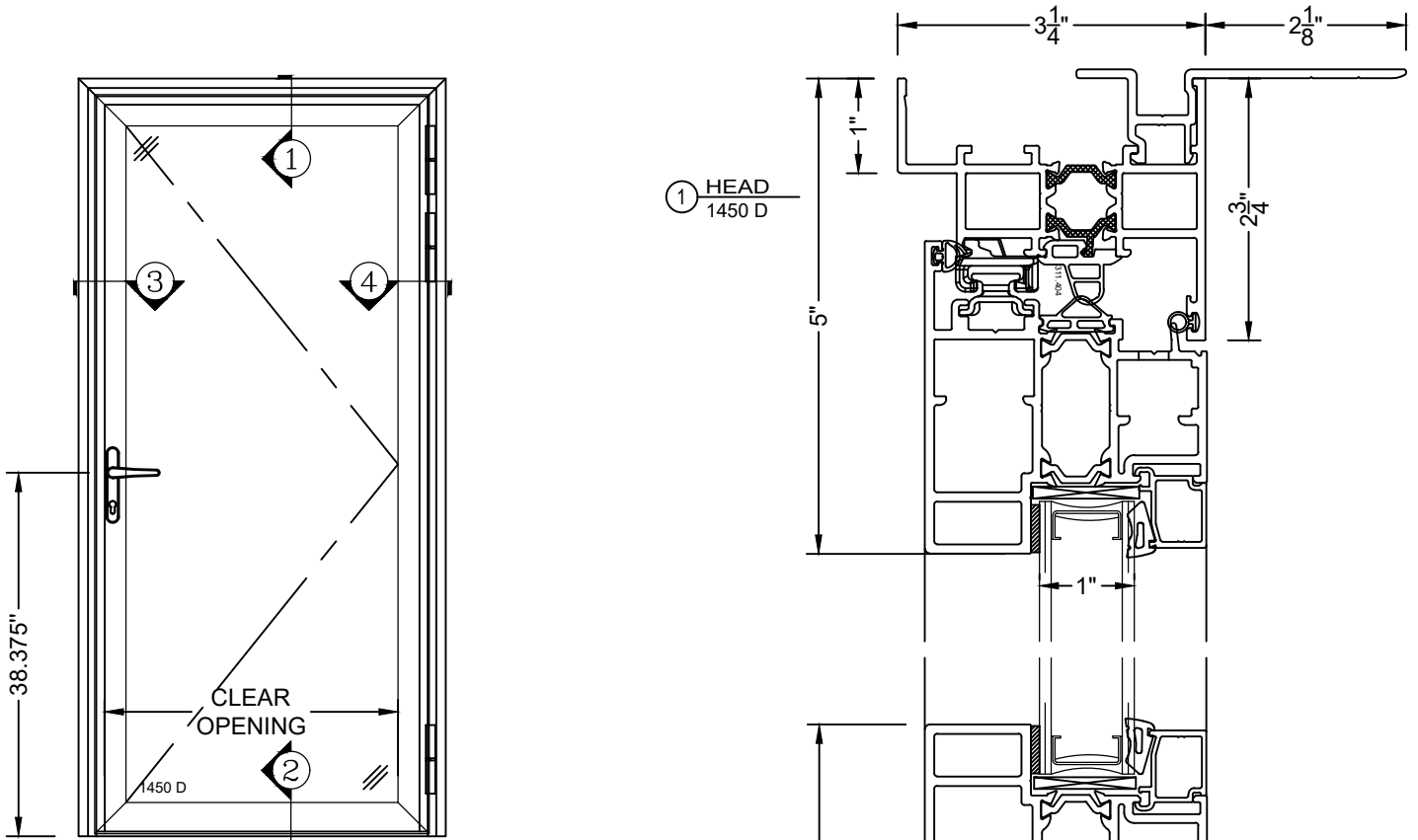

1450 OUT-SWING ADA THRESHOLD

-PLEASE CONTACT YOUR SALE REP. FOR TEST RESULT AND KICK PLATE OPTION

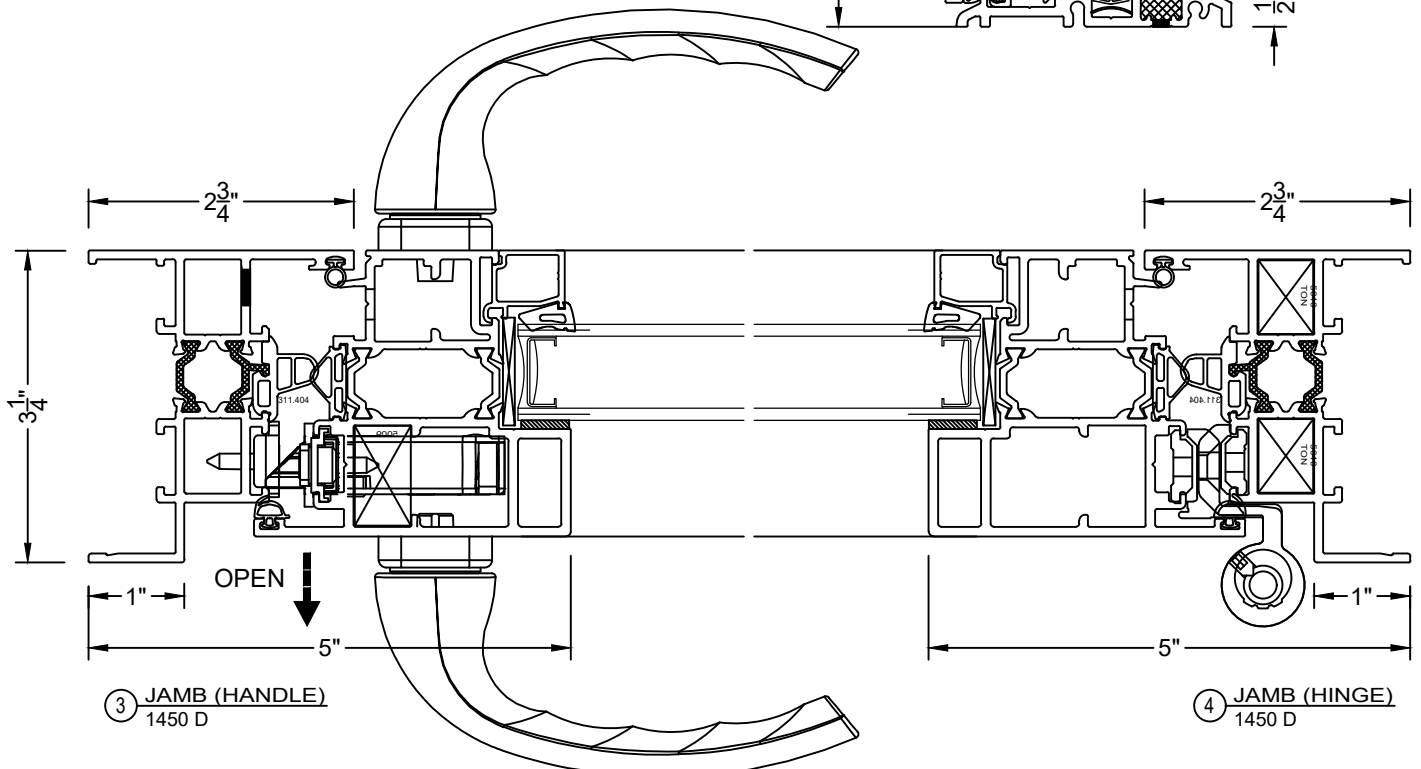

VER: 2025.02

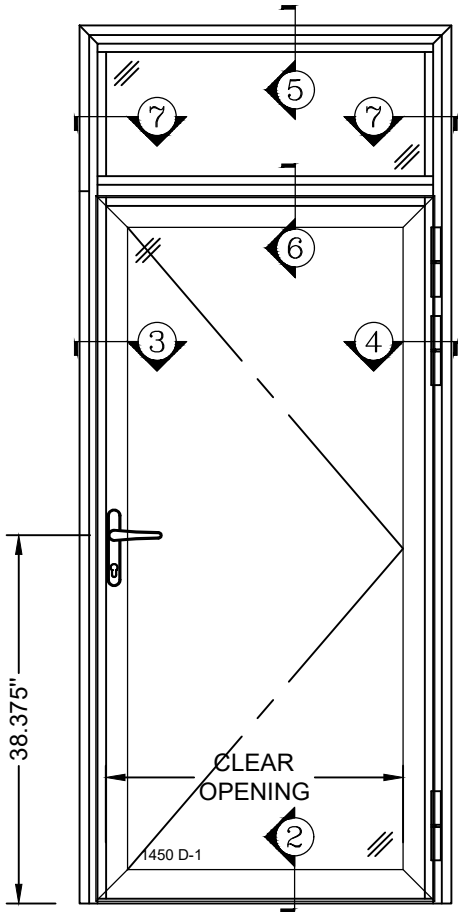

1450 OUT-SWING ADA THRESHOLD
W/ TRANSOM

**-PLEASE CONTACT YOUR SALE REP. FOR
TEST RESULT AND KICK PLATE OPTION**

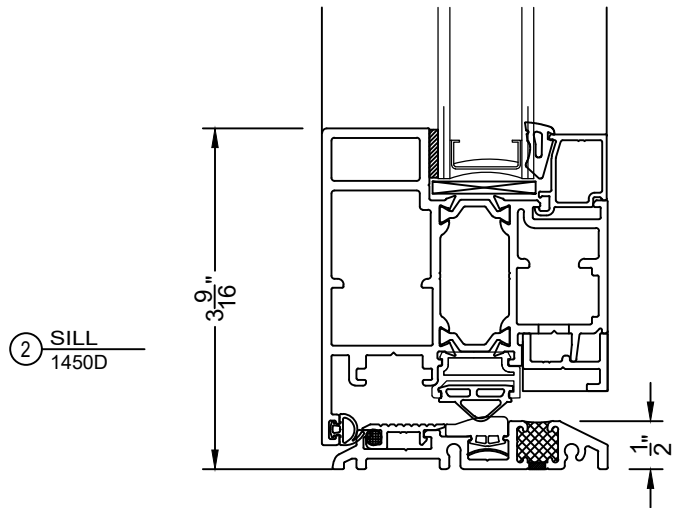
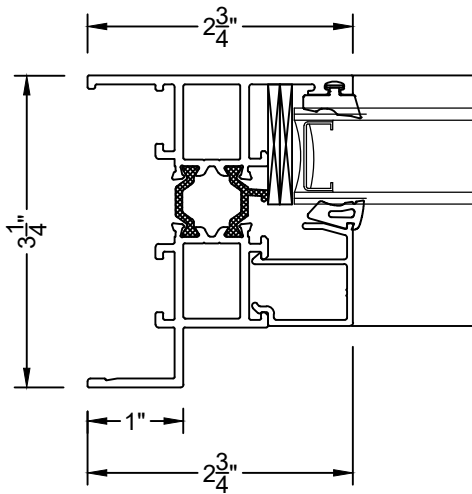
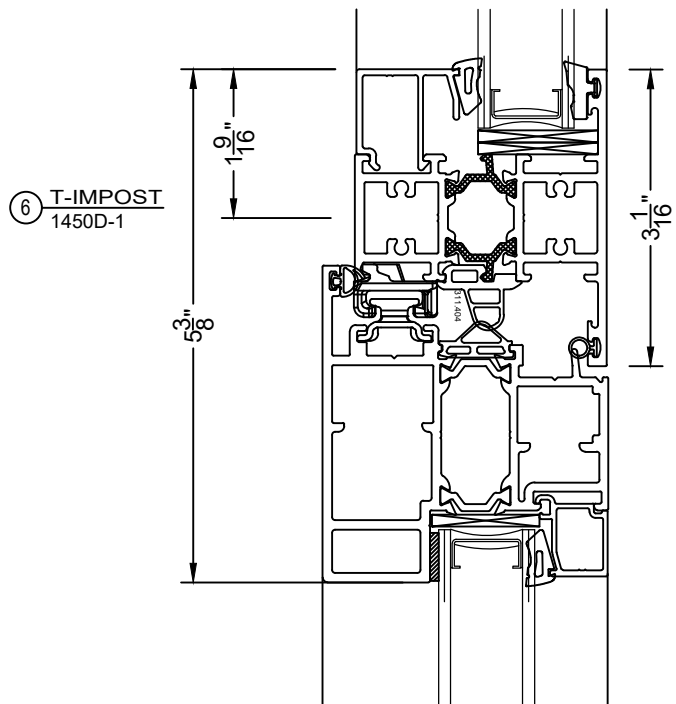
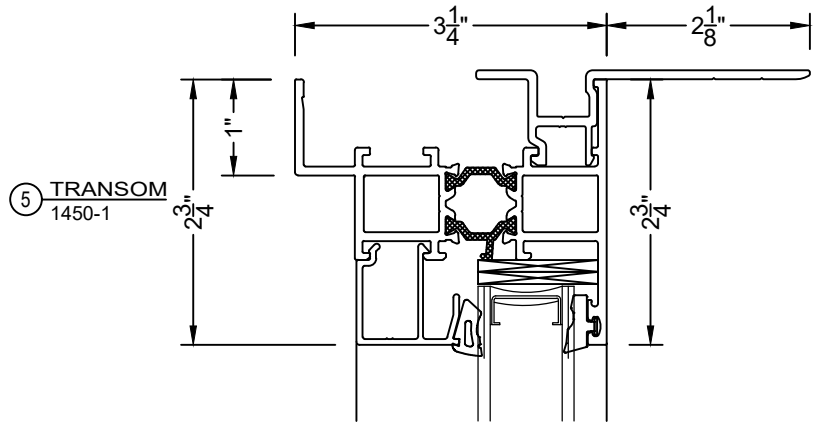

⑦ JAMB (TRANSOM)
1450-1

② SILL
1450D

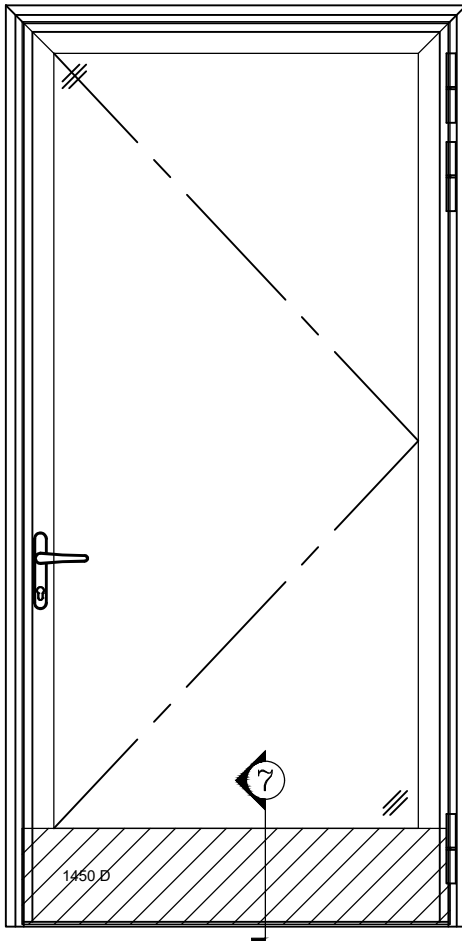

1450 OUT-SWING ADA THRESHOLD
WITH 10" KICK PLATE

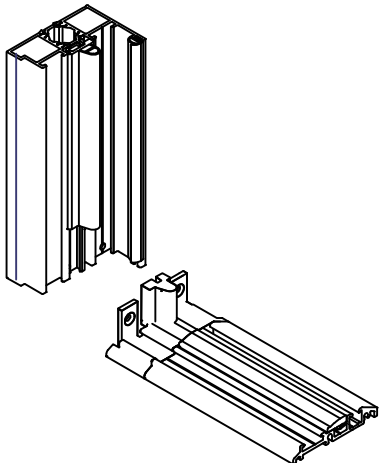
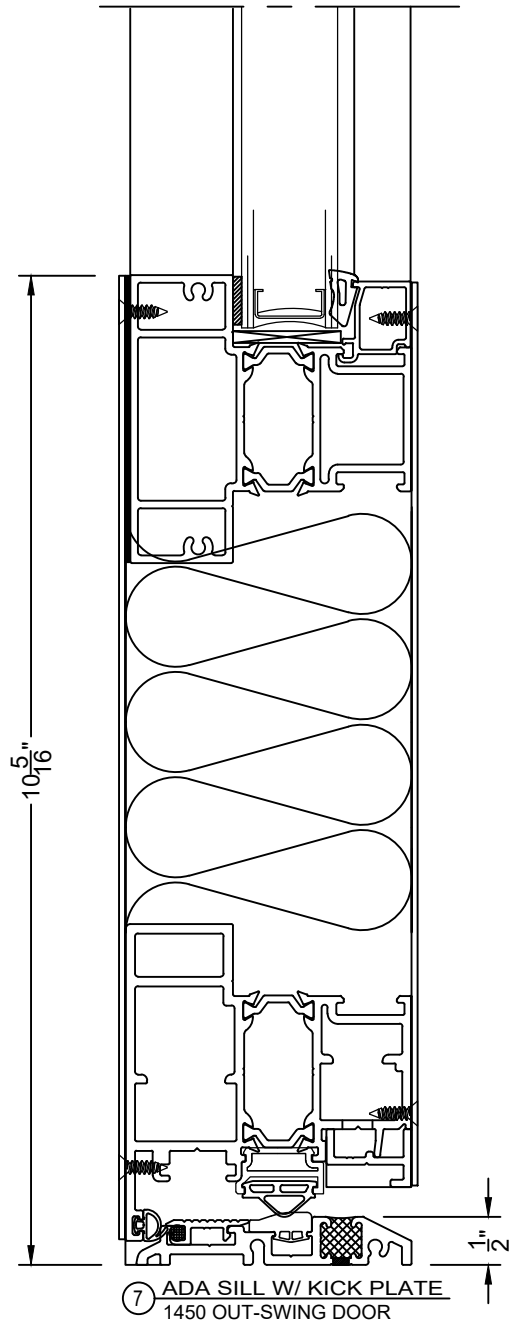

REMOVABLE THRESHOLD

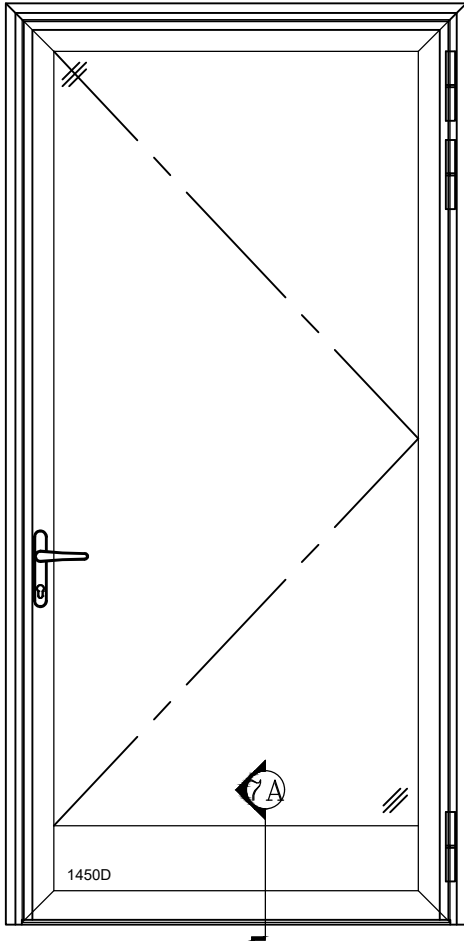

1450 OUT-SWING ADA THRESHOLD
WITH EXTRUDED KICK PLATE

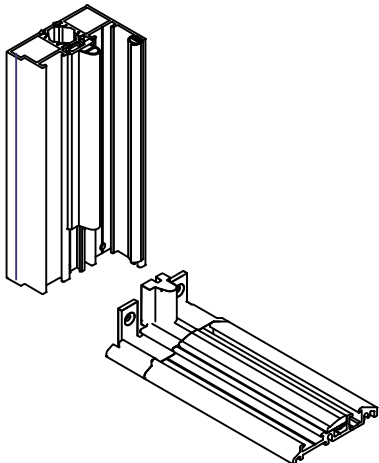

REMOVABLE THRESHOLD

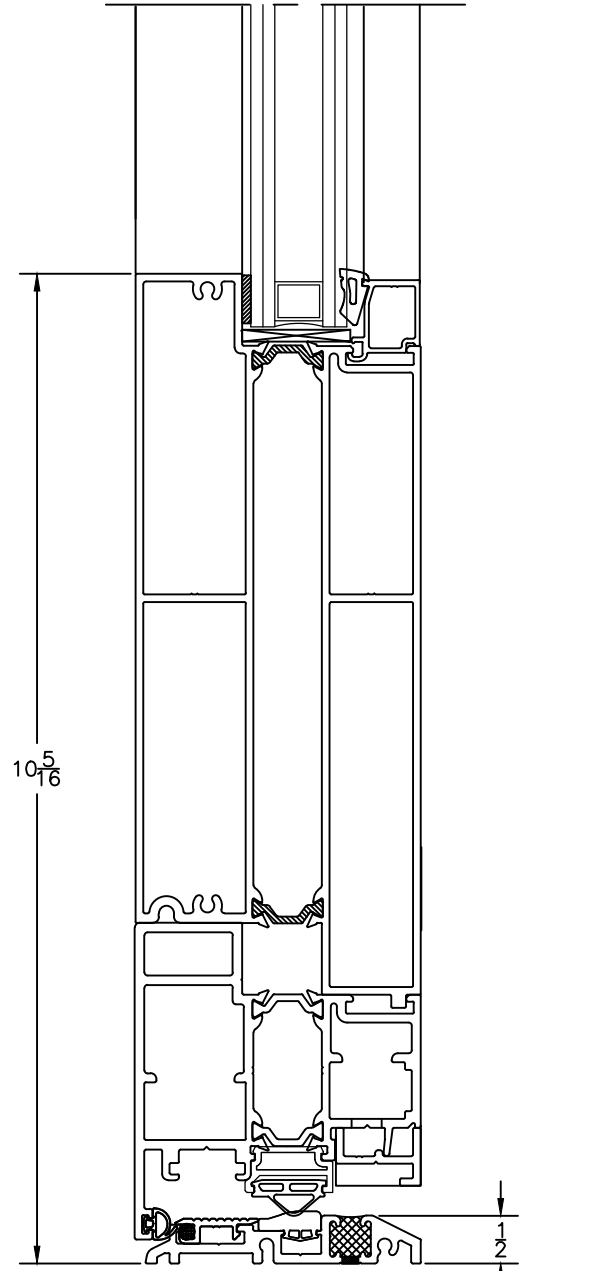

7A ADA SILL W/ EXTRUDED KICK PLATE
1450 OUT-SWING DOOR

MINIMALIST HANDLE DESIGN AND KEYED
CYLINDER OPTION FOR BALCONY
OUT-SWING DOOR

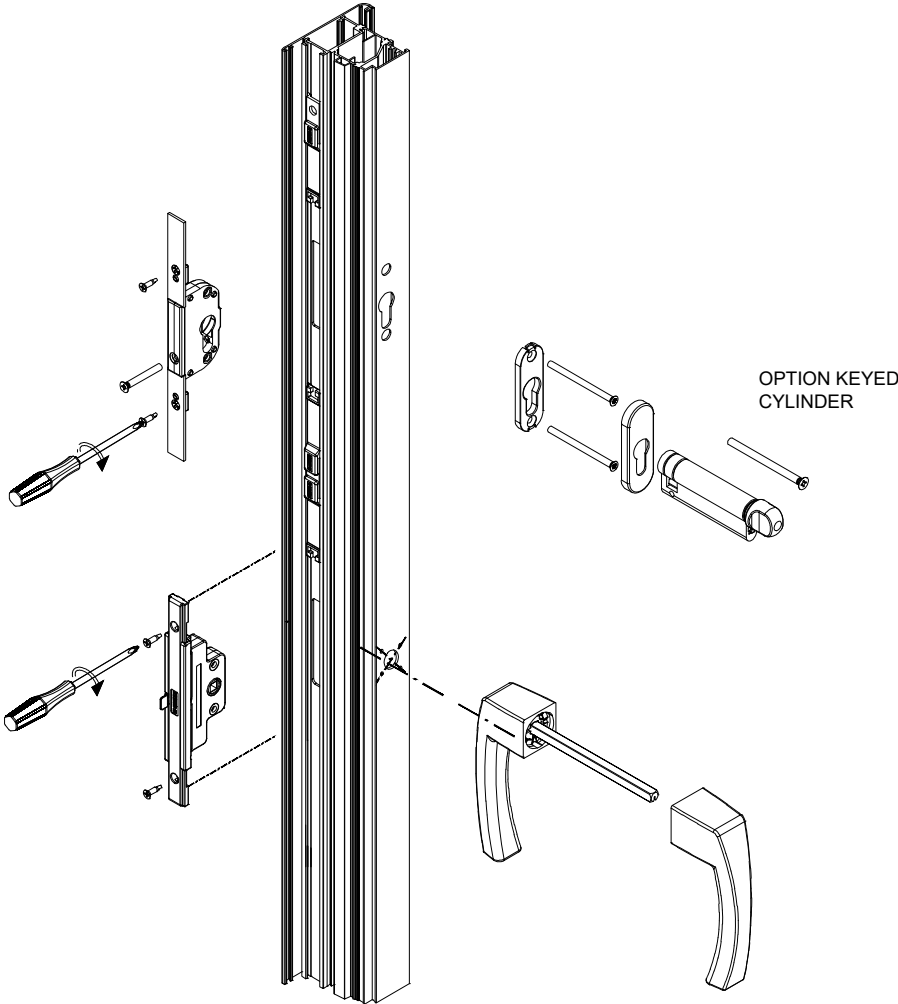

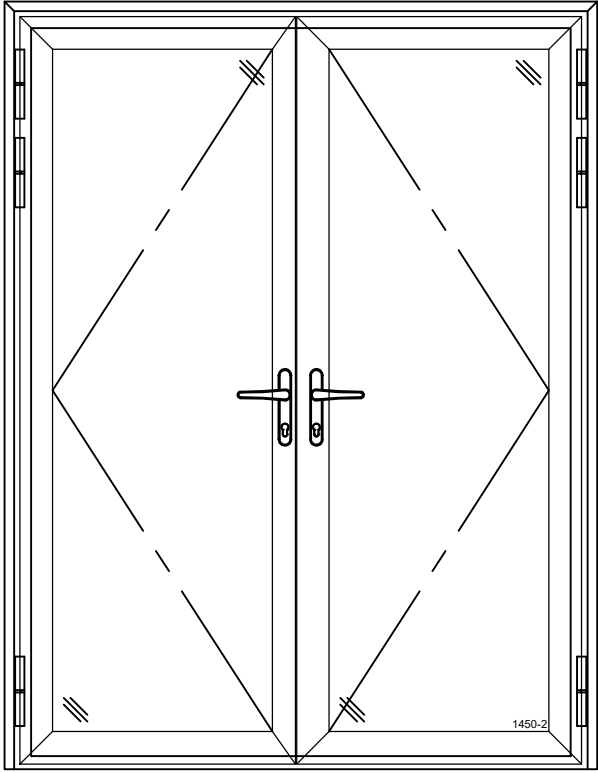

DUMMY HANDLE OPTION
FOR 1450-2 INACTIVE PANEL

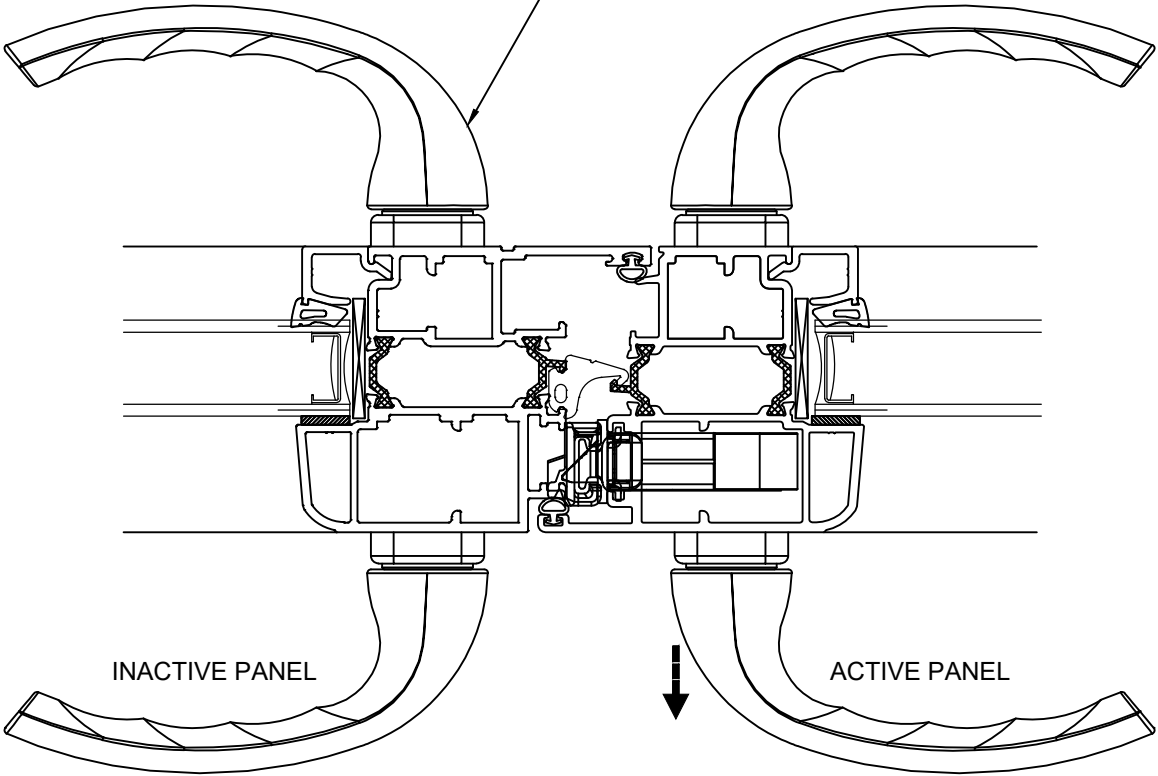

VER: 2025.02