

SERIES 2300 HORIZONTAL SLIDING WINDOWS

TEST SIZE W x H	AAMA RATING	AIR INFILTRATION	DESIGN PRESSURE	WATER RESISTANCE	U-VALUE	SHGC	VT
71" x 59 ¹ / ₄ "	CW-PG50	≤0.30 cfm/ft ²	50 psf	7.5 psf	0.39-0.61	0.17-0.60	0.31-0.62

TABLE OF CONTENT

- INTRODUCTION -P1
- TWO LITE SLIDER -P2
- THREE LITE SLIDER -P3
- MULLION -P4-P5
- NAIL FIN -P6
- FACE FLANGE -P7-P8

FEATURES

- ALUMINUM THERMAL-BREAK HORIZONTAL SLIDING WINDOW
- 3-1/4" FRAME DEPTH
- 7/8" DOUBLE PANE INSULATED GLASS
- AAMA 2604 POWDER COAT PAINT
- CORROSION RESISTANT TWO-WHEEL BRASS ROLLERS
- REMOVABLE SASHES
- MEETING RAIL LOCK(S)
- HALF SCREEN

OPTIONAL SELECTIONS

- LOW-E COATING & ARGON FILLED IGU
- 1-1/2" NAILING FIN (1-1/8" SETBACK)
- 1-1/2" OR 2-1/2" FACE FLANGE
- CUSTOM FINISH AND CUSTOM COLOR
- GRIDS
- VINYL SASH STOPS
- FULL SCREEN
- OTHER OPTIONAL ACCESSORIES

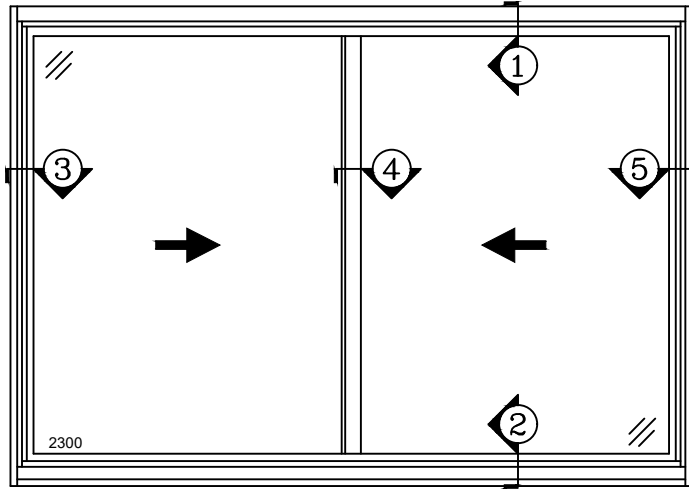

2300-2 TWO LITE SLIDER

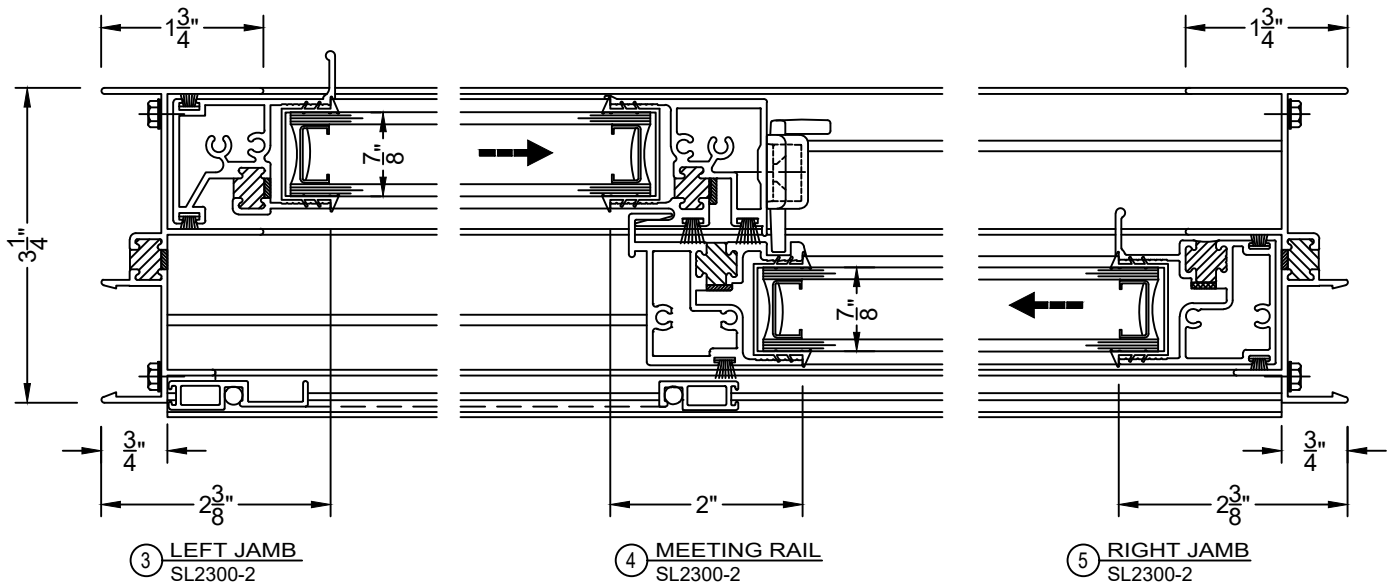
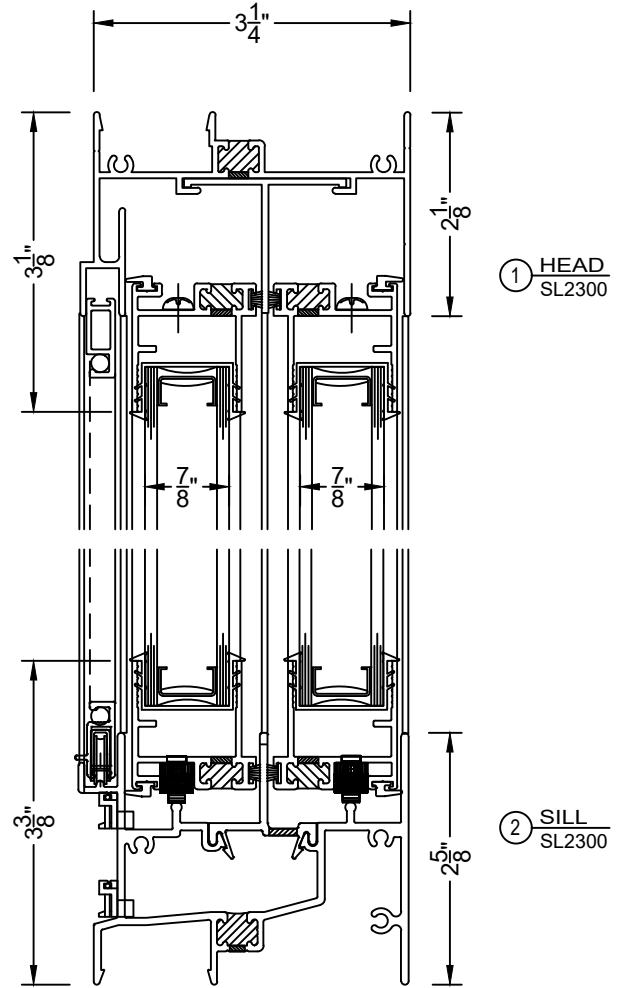

VER: 2020.03

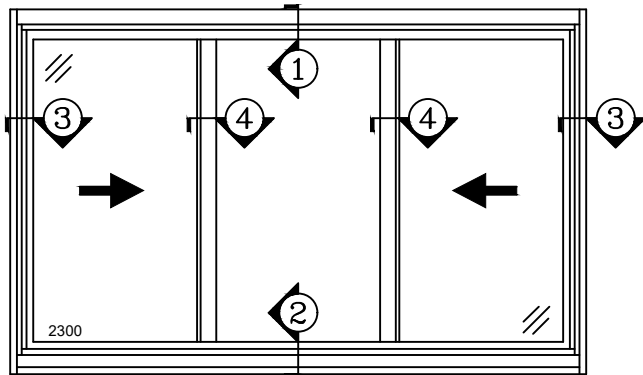

2300-3 THREE LITE SLIDER EQUAL LITE (X-O-X)

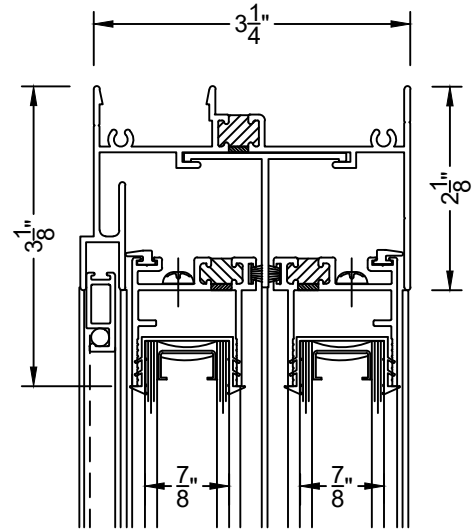

① HEAD
SL2300

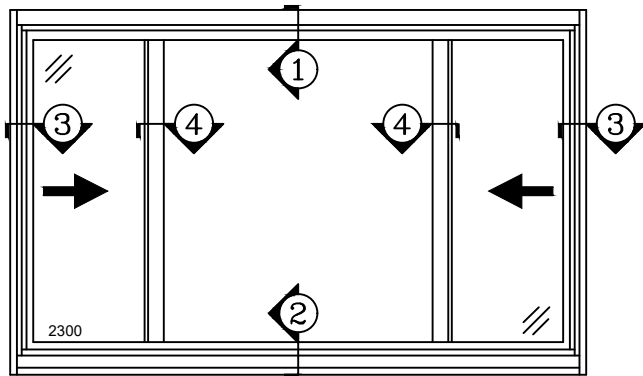

2300-3 THREE LITE SLIDER UNEQUAL LITE (X-O-X)

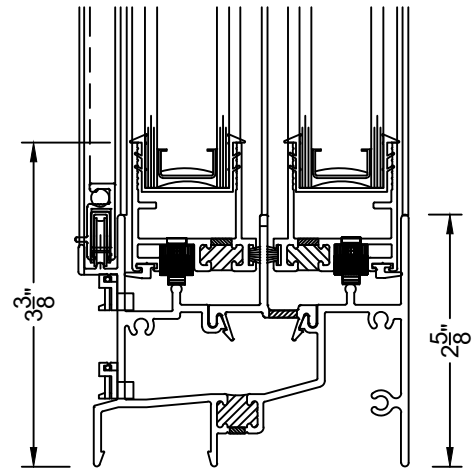

② SILL
SL2300

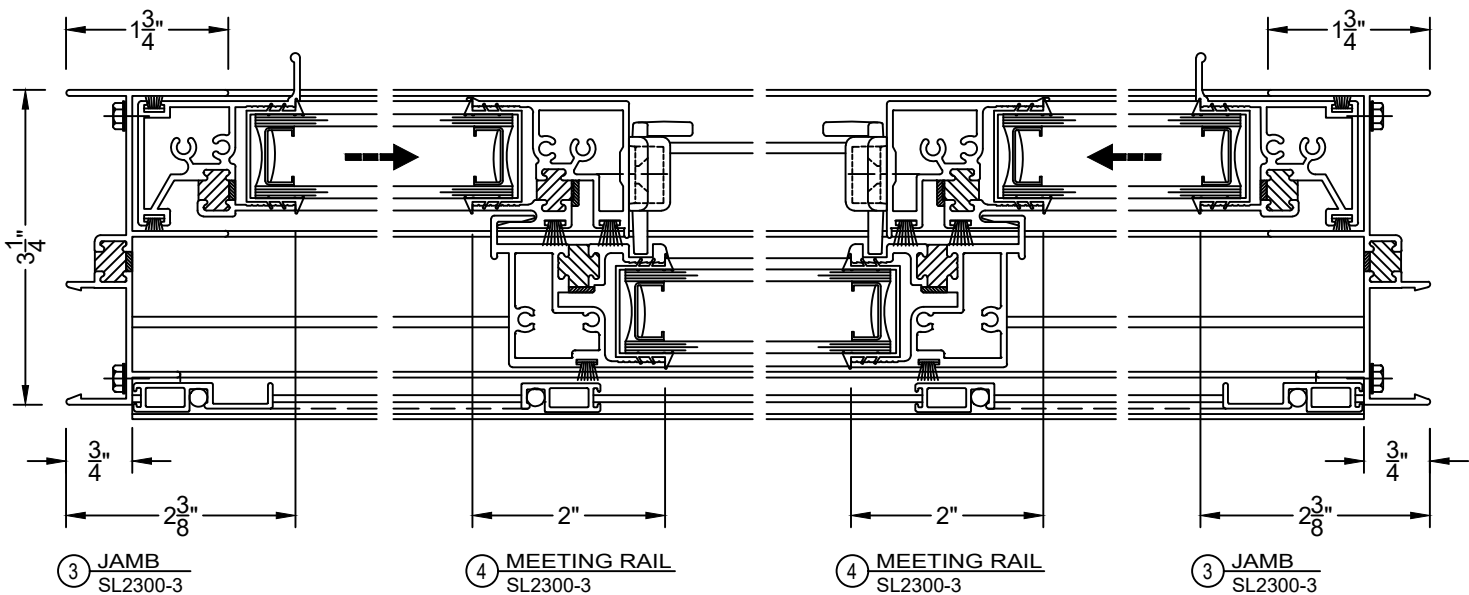

③ JAMB
SL2300-3

④ MEETING RAIL
SL2300-3

④ MEETING RAIL
SL2300-3

③ JAMB
SL2300-3

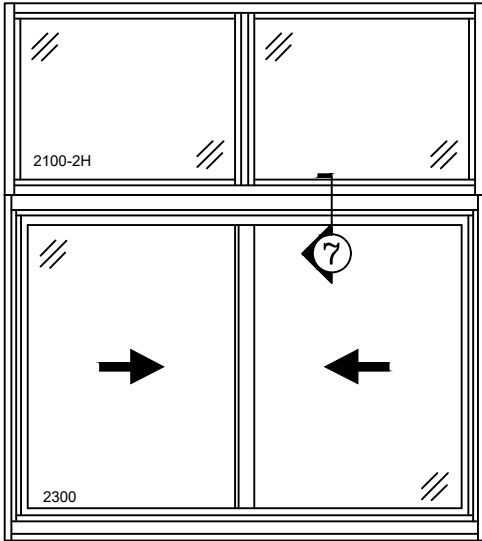

PW2100T OVER SL2300-2

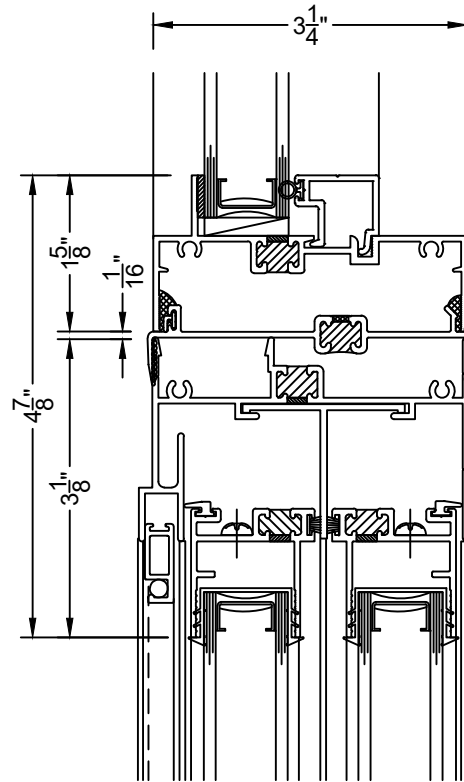

7 STACK MULLION
PW2100 OVER SL2300

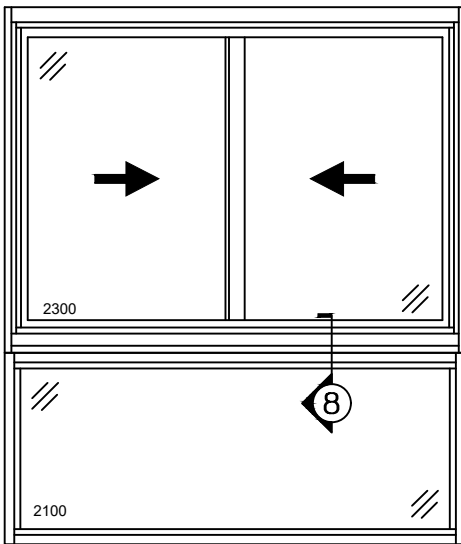

SL2300-2 & PW2100

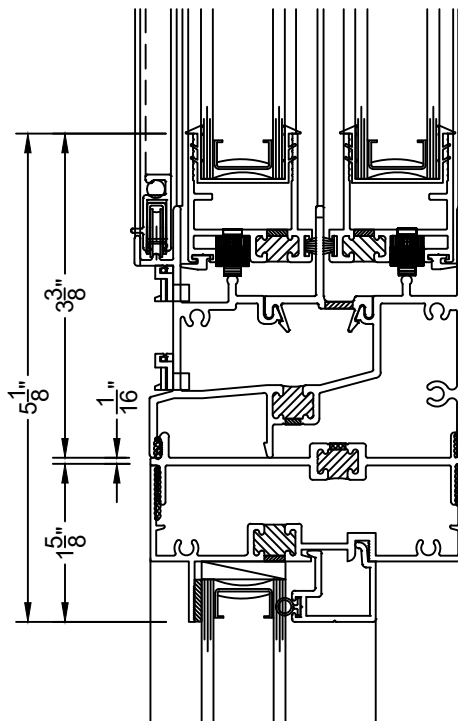

8 SHORT LEG STACK MULLION
SL2300 OVER PW2100

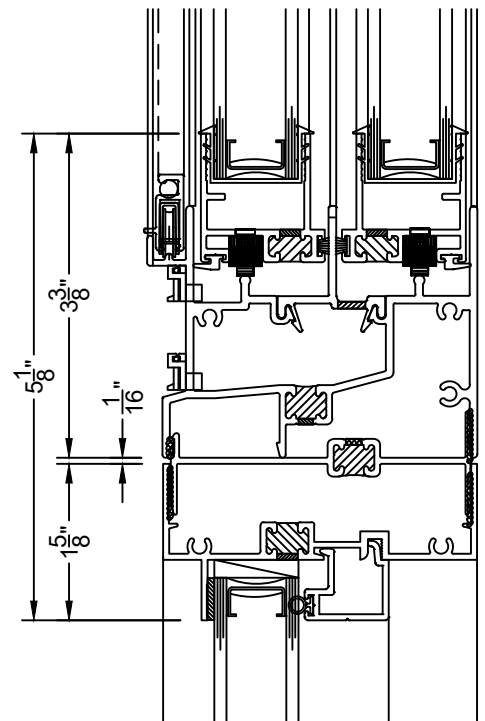

8A SHORT LEG H MULLION
SL2300 OVER PW2100

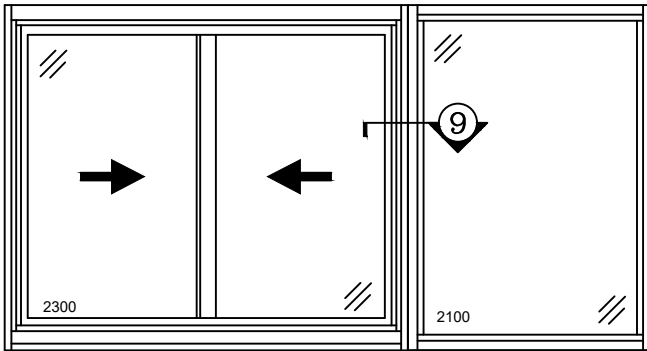

SL2300-2 & PW2100

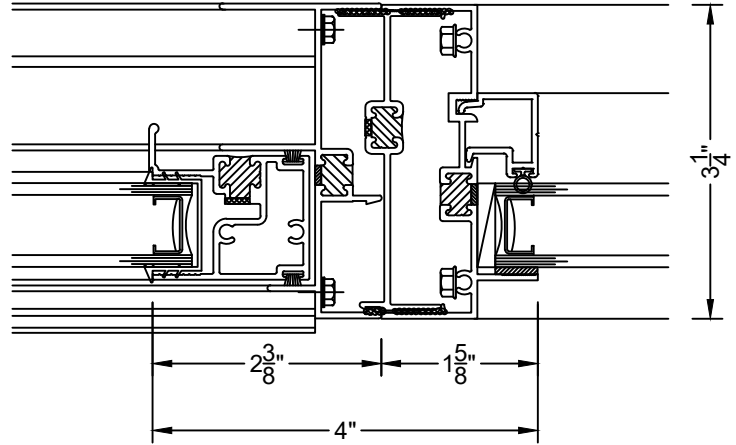

⑨ SHORT LEG H MULLION
SL2300 & 2100 PW

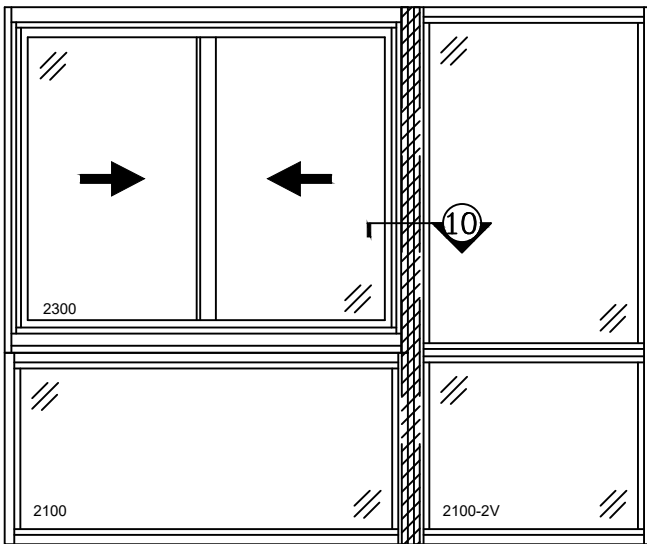

SL2300 OVER PW2100 & PW2100-2V
W/ 3PC MULLION

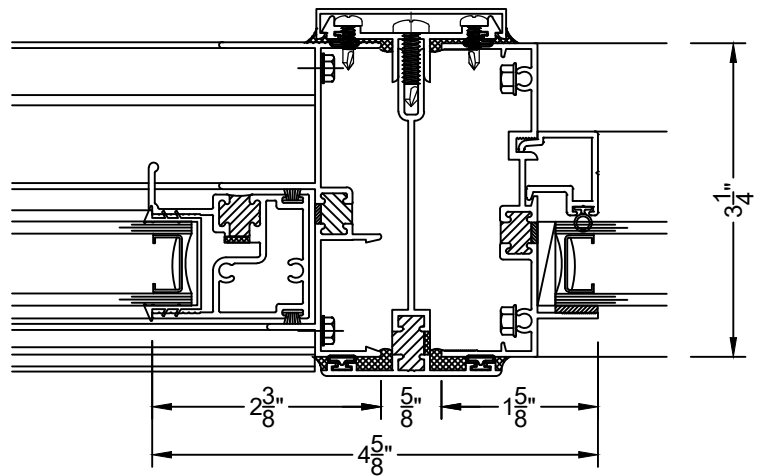

⑩ 3PC MULLION
SL2300 & 2100 PW

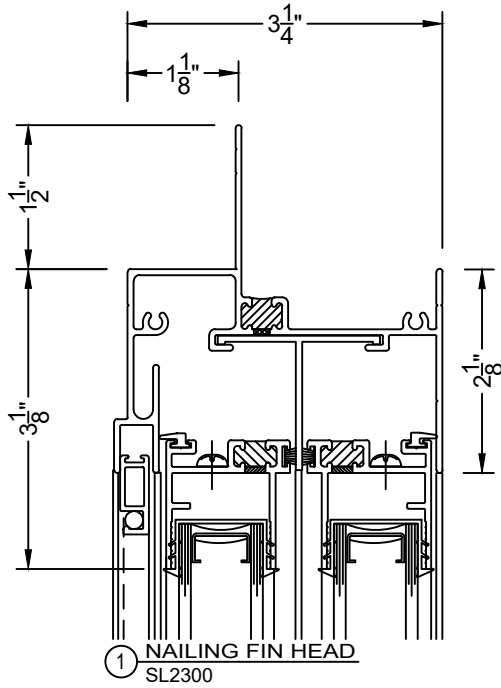

① NAILING FIN HEAD
SL2300

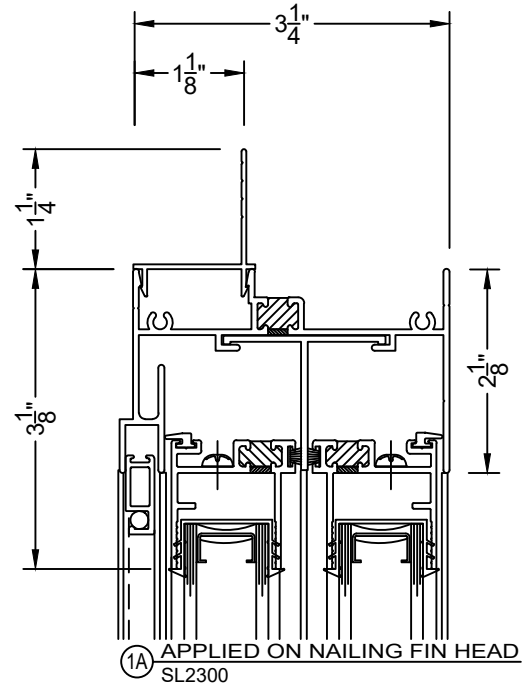

①A APPLIED ON NAILING FIN HEAD
SL2300

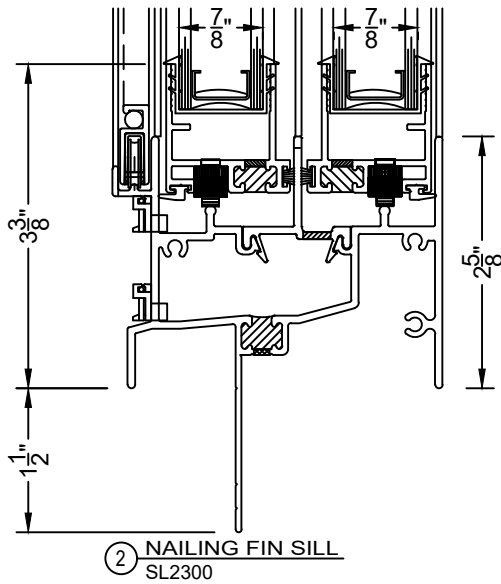

② NAILING FIN SILL
SL2300

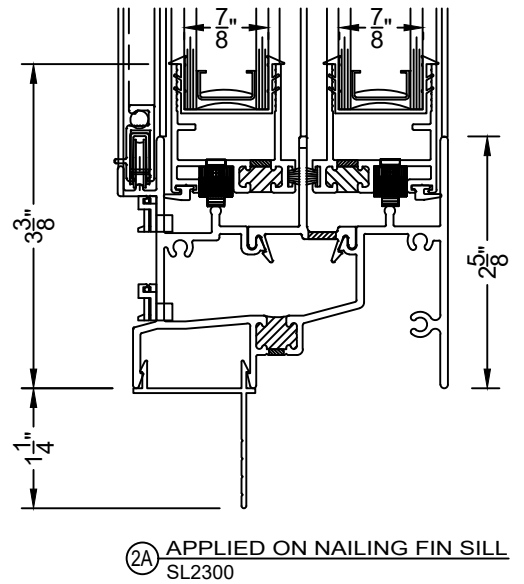

②A APPLIED ON NAILING FIN SILL
SL2300

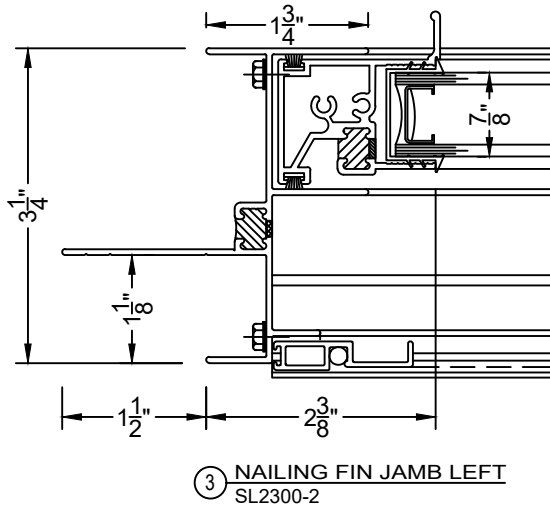

③ NAILING FIN JAMB LEFT
SL2300-2

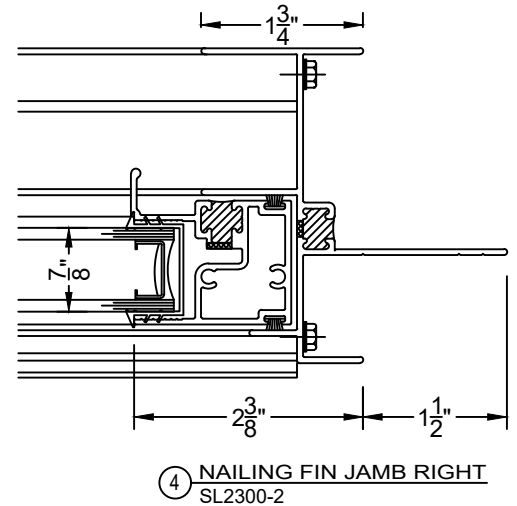

④ NAILING FIN JAMB RIGHT
SL2300-2

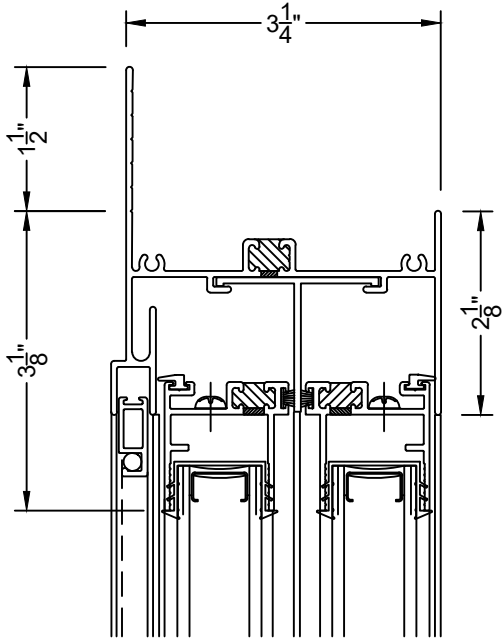

① 1-1/2" FLANGE HEAD
SL2300

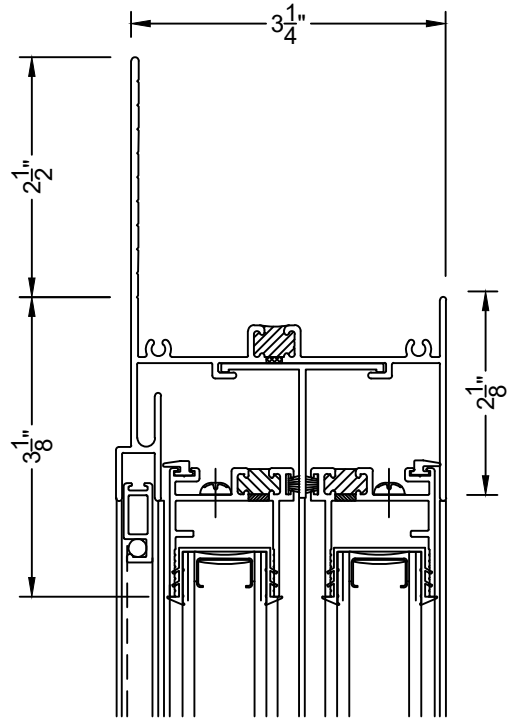

①A 2-1/2" FLANGE HEAD
SL2300

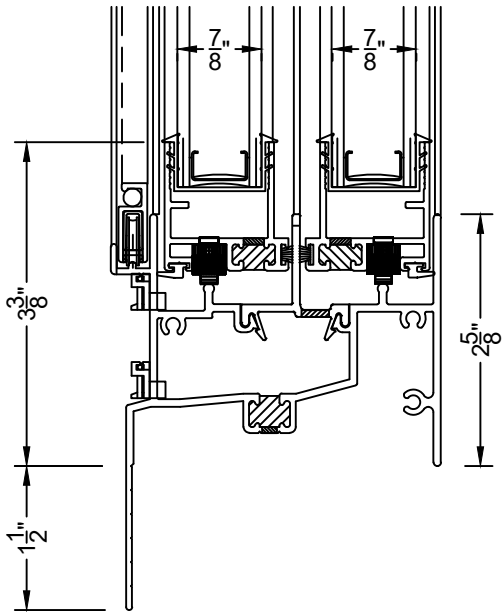

② 1-1/2" FLANGE SILL
SL2300

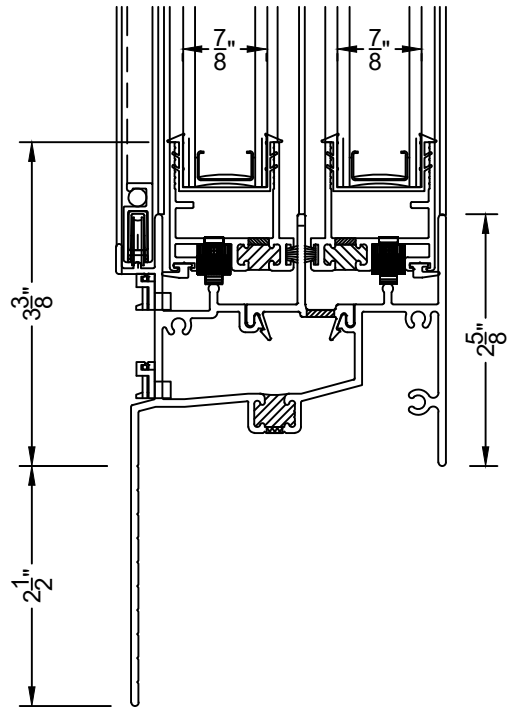

②A 2-1/2" FLANGE SILL
SL2300

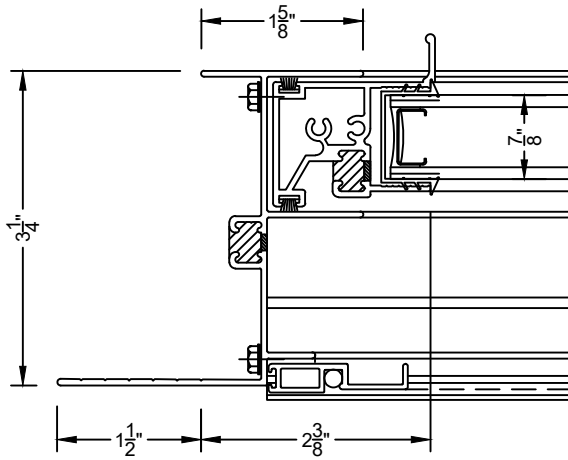

③ 1-1/2" FLANGE JAMB LEFT
SL2300

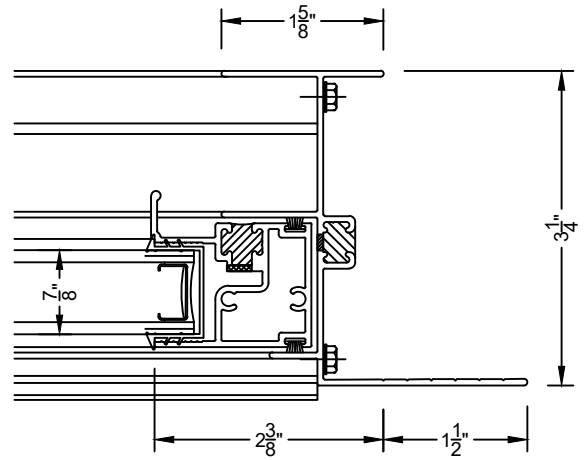

④ 1-1/2" FLANGE JAMB RIGHT
SL2300

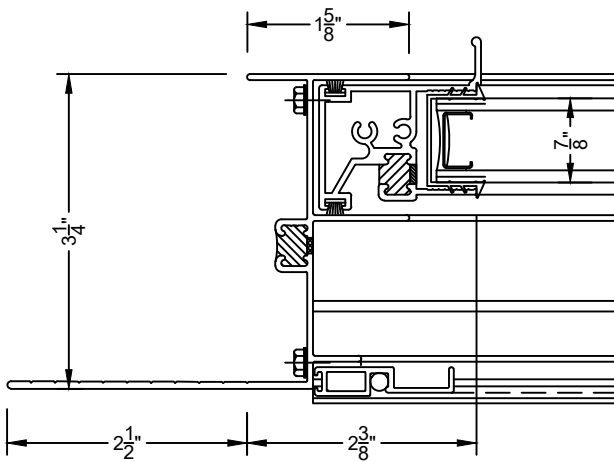

③A 2-1/2" FLANGE JAMB LEFT
SL2300

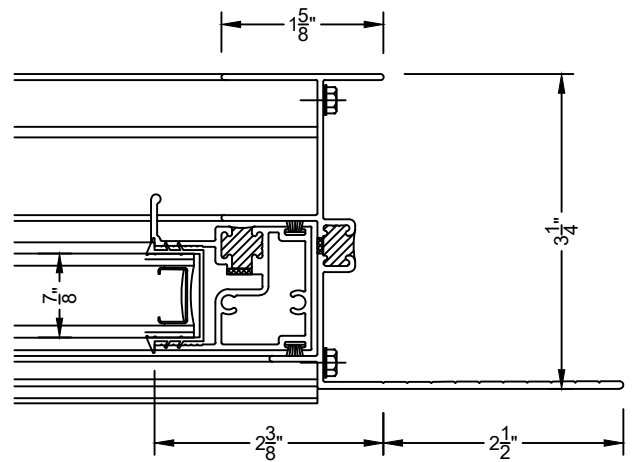

④A 2-1/2" FLANGE JAMB RIGHT
SL2300