

SERIES 2700 DOUBLE HUNG WINDOW

TEST SIZE W X H	AAMA RATING	AIR INFILTRATION	DESIGN PRESSURE	WATER RESISTANCE	U-FACTOR	SHGC	VT
56" x 91"	CW-PG50	≤0.30 cfm/ft ²	50 psf	7.5 psf	0.33-0.59	0.18-0.58	0.32-0.61
60" x 99"	AW-PG50	≤0.30 cfm/ft ²	50 psf	10 psf			

TABLE OF CONTENT

- CW SECTION DETAIL -P2
- AW SECTION DETAIL -P3
- FIXED SECTION DETAIL -P4
- MULLION DETAIL -P5-P6
- FRAME OPTIONS -P7-P10

FEATURES

- WIDE ALUMINUM THERMAL BREAK WINDOW
- 3-1/4" FRAME DEPTH
- 1" DOUBLE PANE INSULATED GLASS
- AAMA 2604 POWDER COAT PAINT
- EQUAL SITELINE DESIGN
- CONTINUOUS WEATHERSTRIP AT MEETING RAIL
- CONTINUOUS SNAP LATCH AT HEAD AND SILL
- 13LBS WINDOW SILL
- SURFACE MOUNTED METAL TILT LATCH

AW FEATURES

- STEEL REINFORCEMENT ON LOCK RAIL
- CONCEALED TILT LATCH AT LOCK RAIL
- ANTI-BOW PIN

OPTIONAL SELECTIONS

- LOW-E COATING & ARGON FILLED IGU
- CUSTOM FINISH AND CUSTOM COLORS
- GRIDS
- HALF OR FULL SCREEN
- MEETING RAIL SWEEP LOCK
- BLOCK & TACKLE OR ULTRA LIFT
- OTHER OPTIONAL ACCESSORIES
- RETURN LEG FRAME

CW SERIES

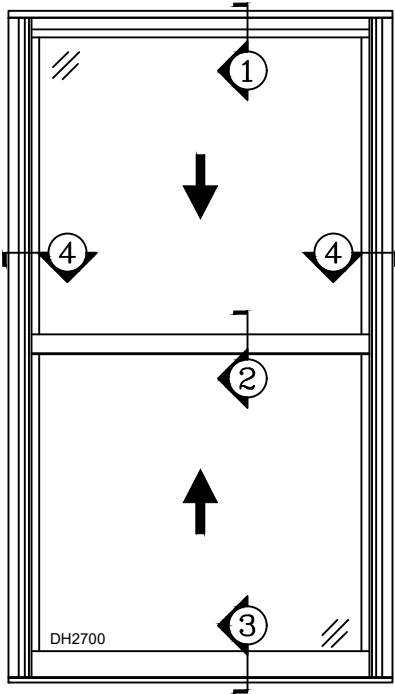

2700 DOUBLE HUNG WINDOW

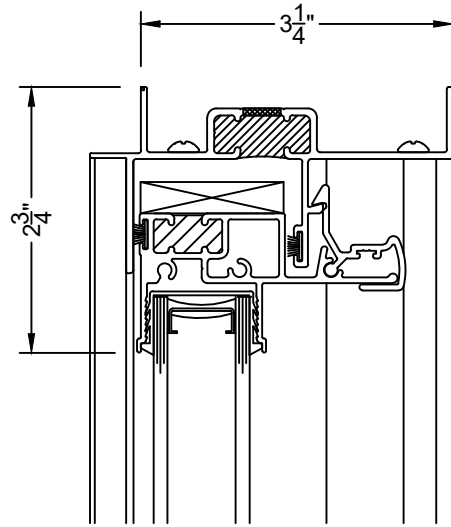

① HEAD
DH2700

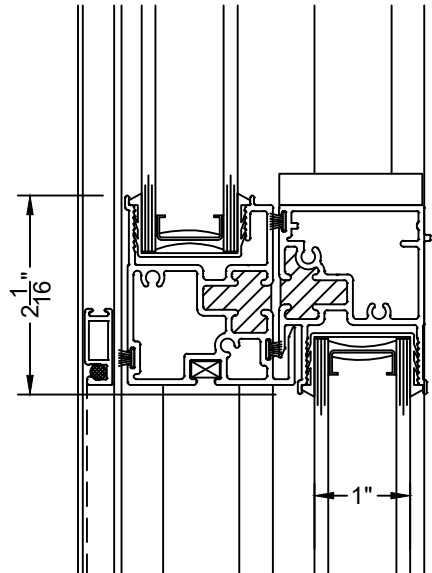

② MEETING RAIL
DH2700

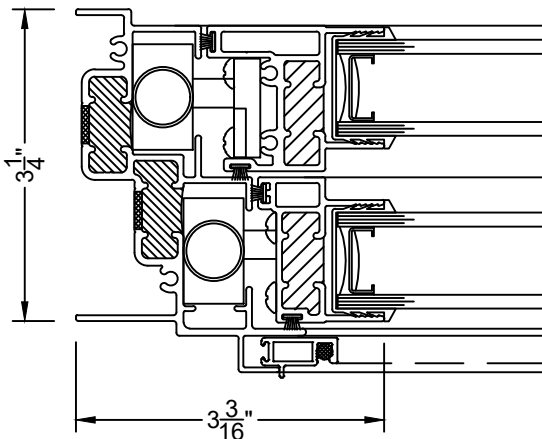

④ JAMB
DH2700

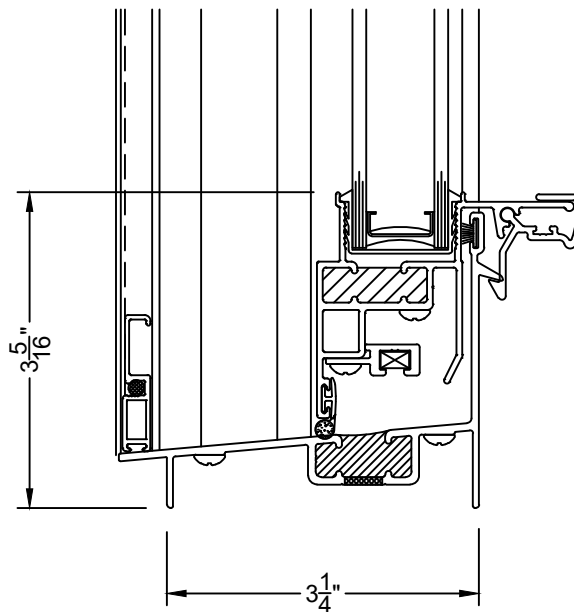

③ SILL
DH2700

AW SERIES

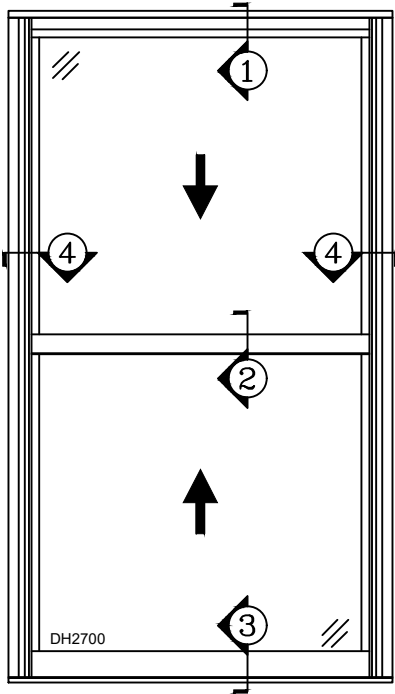

2700 DOUBLE HUNG WINDOW

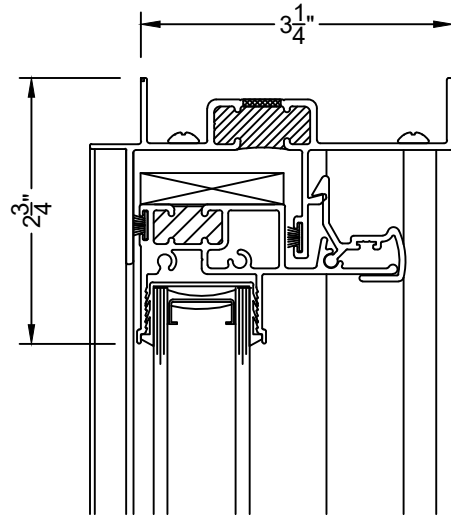

① HEAD
DH2700

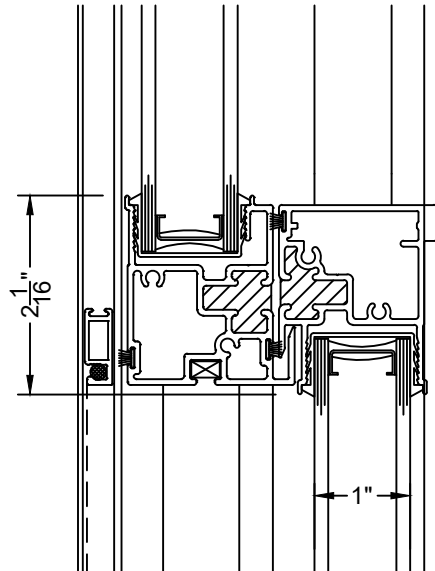

②A MEETING RAIL
DH2700

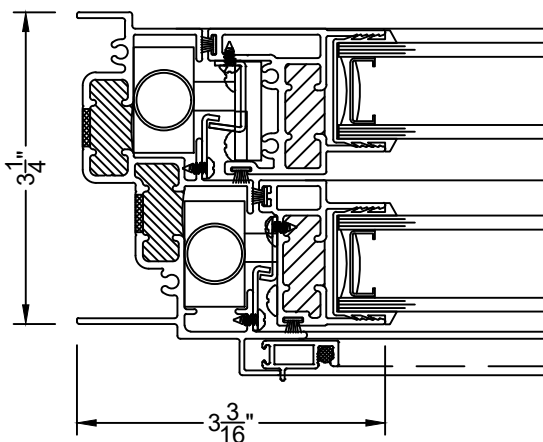

④A JAMB
DH2700

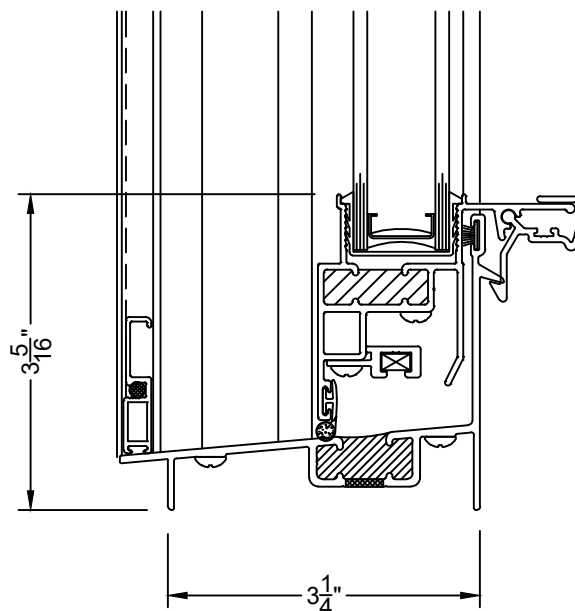

③ SILL
DH2700

FIXED

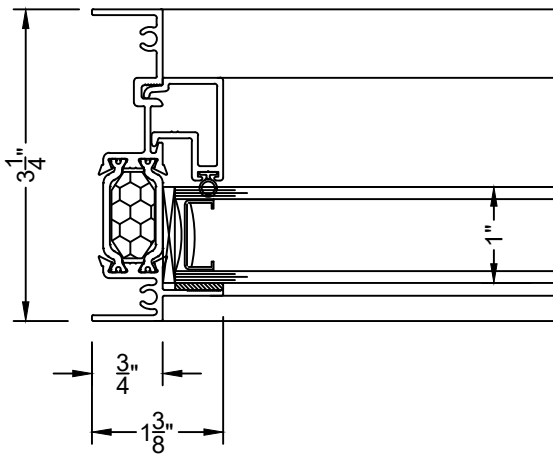
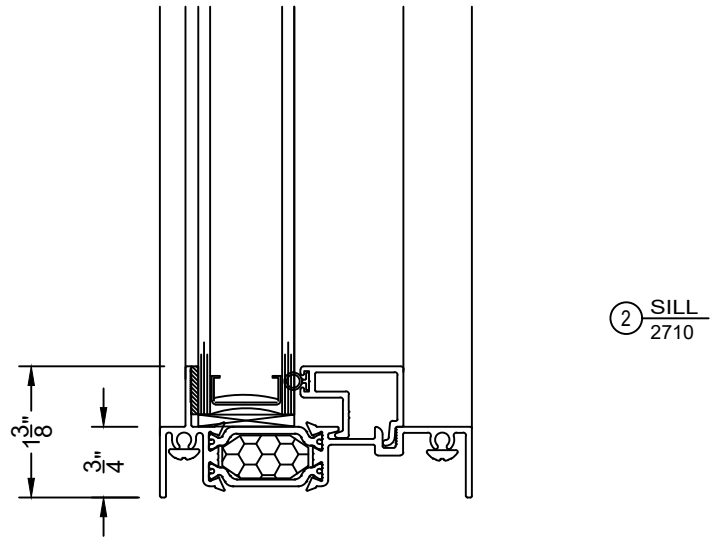
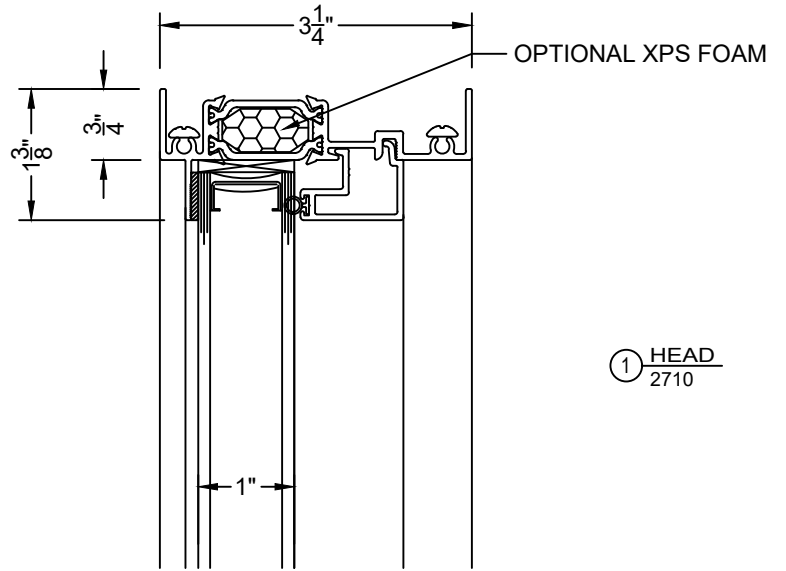
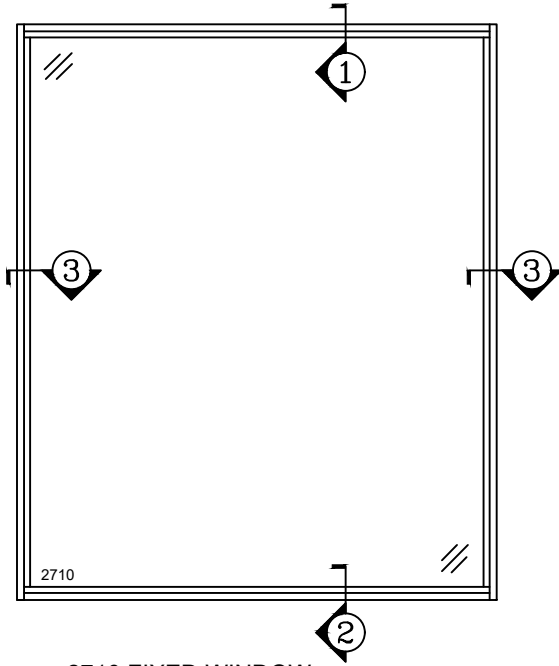

③ JAMB
2710

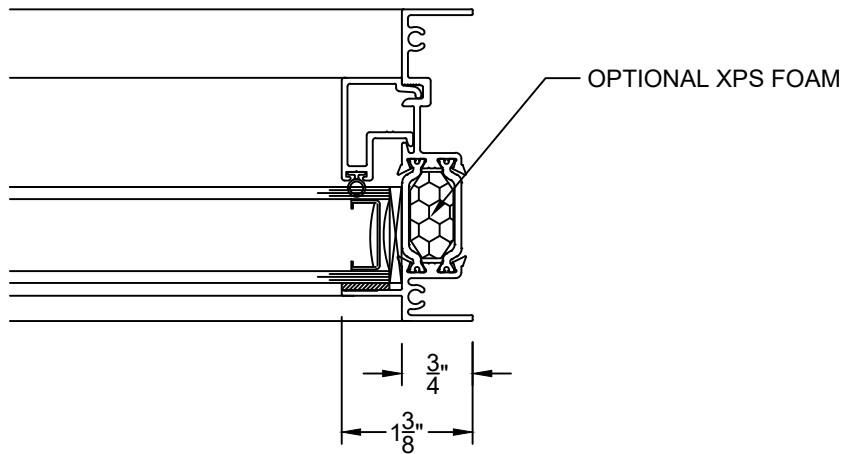

③ JAMB
2710

VER: 2024.07

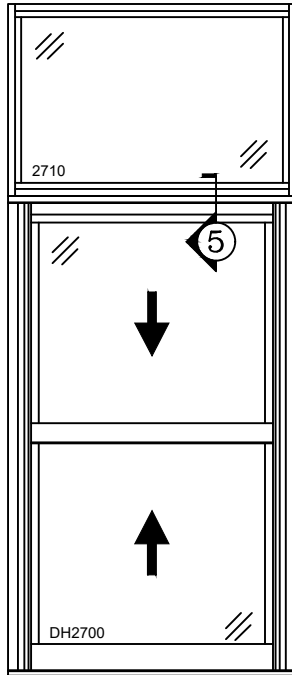

2710 OVER DH2700

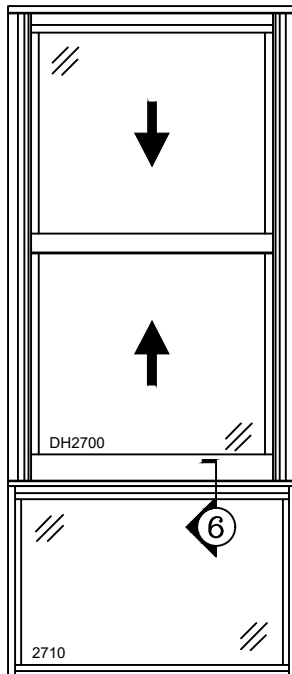
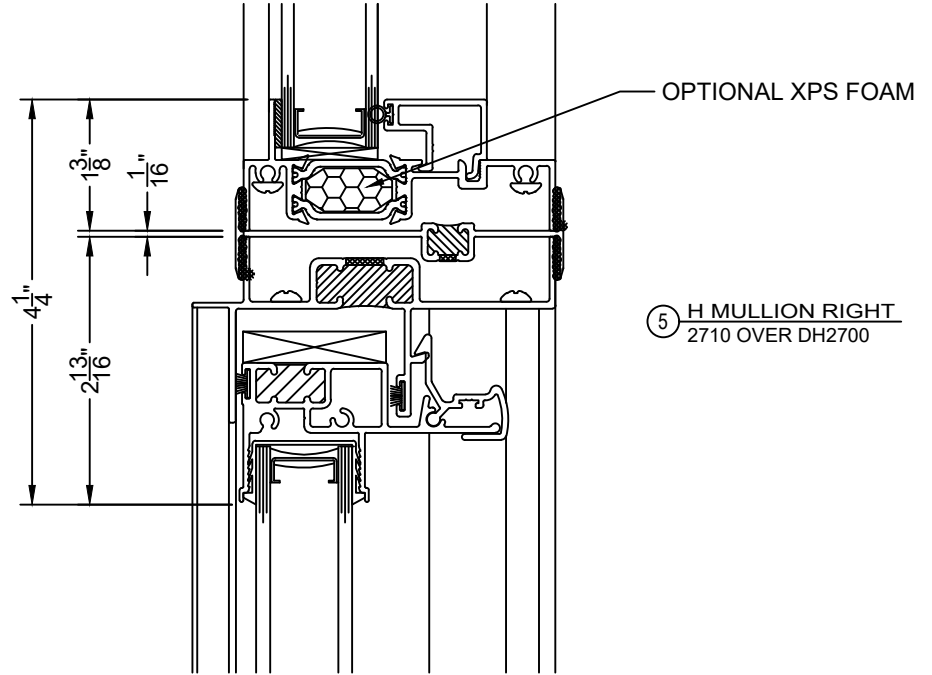

DH2700 OVER 2710

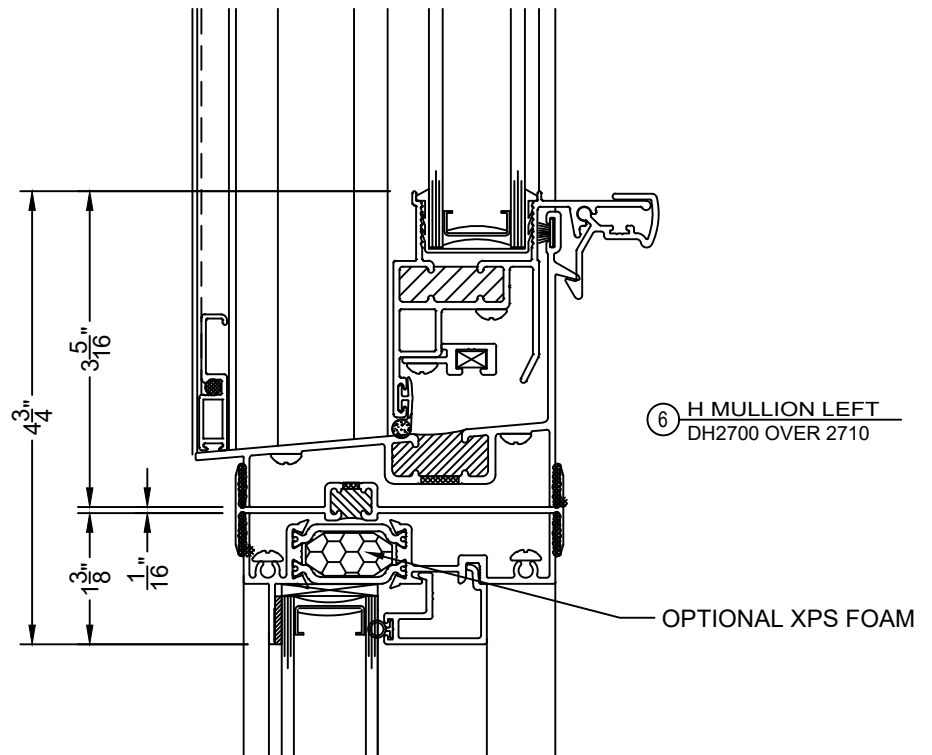

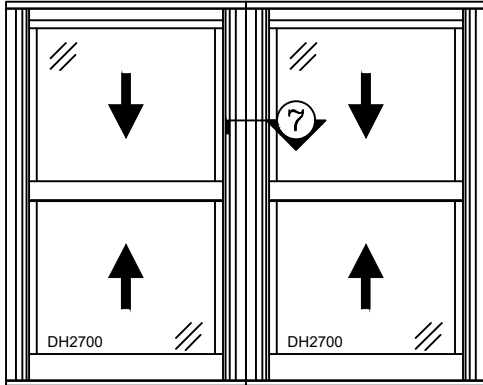

DH2700 & DH2700

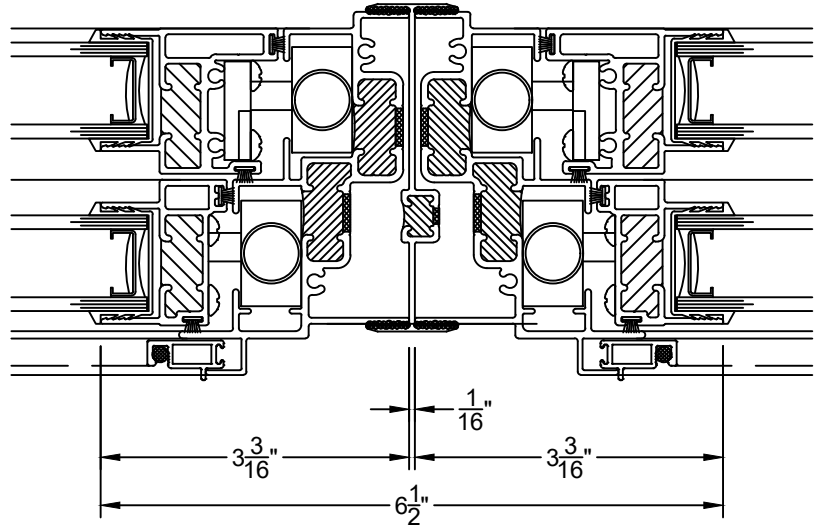

⑦ H MULLION LEFT
DH2700 & DH2700

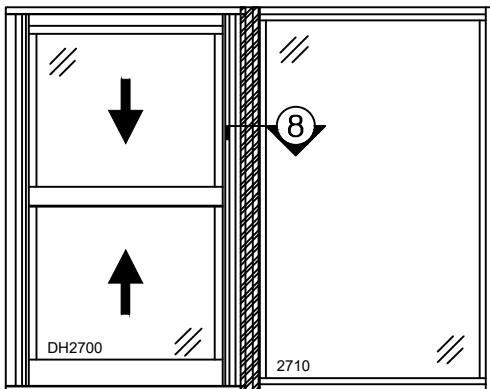

2700DH & 2710

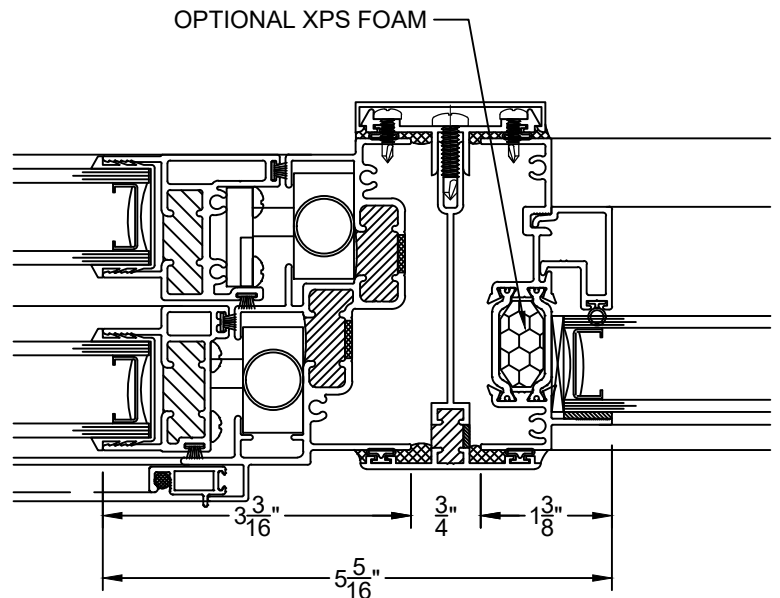

⑧ 3PC MULLION
DH2700 & 2710

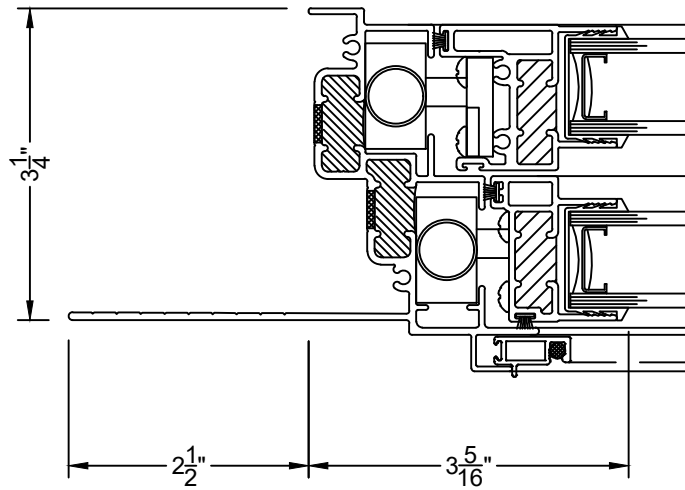

④C 2.5" FLANGE JAMB
DH2700

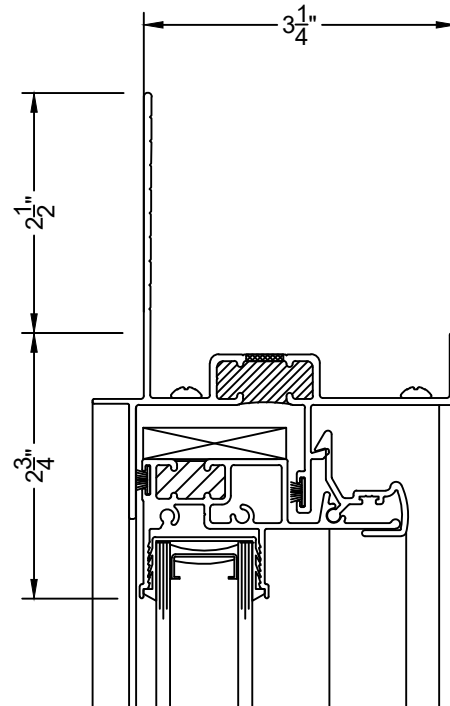

①C 2.5" FLANGE HEAD
DH2700

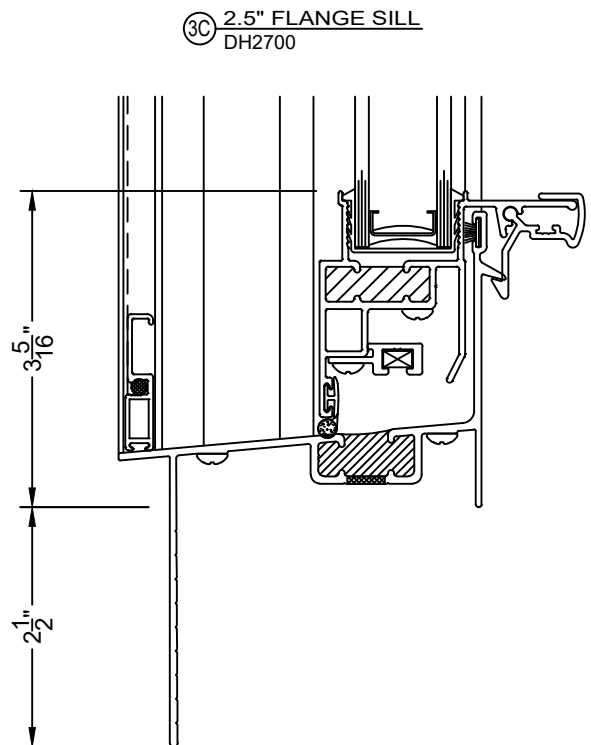

③C 2.5" FLANGE SILL
DH2700

VER: 2024.07

③B 2.5 FLANGE JAMB
2710

③B 2710

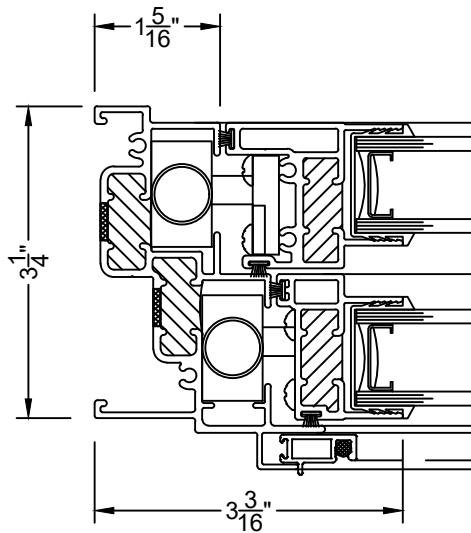

④D RETURN LEG JAMB
DH2700

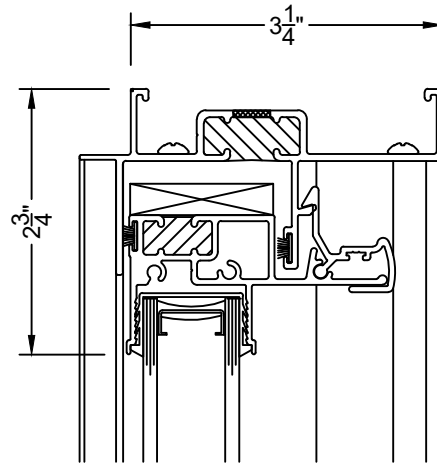

①D RETURN LEG HEAD
DH2700

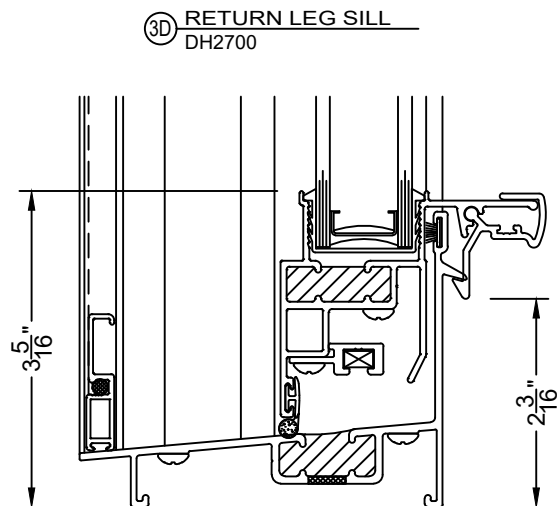

③D RETURN LEG SILL
DH2700

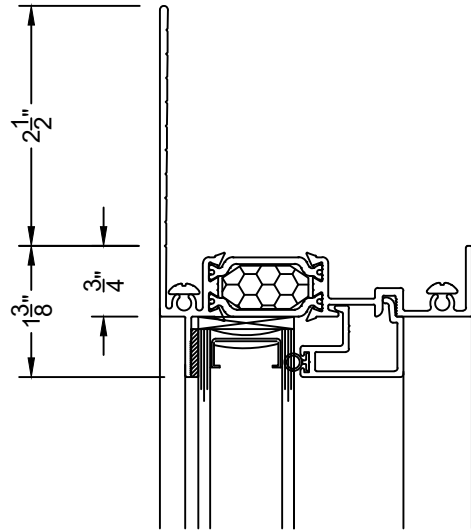

①B 2.5 FLANGE HEAD
2710

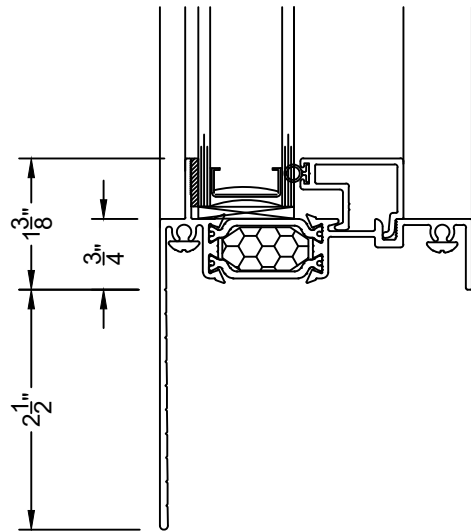

②B 2.5 FLANGE SILL
2710

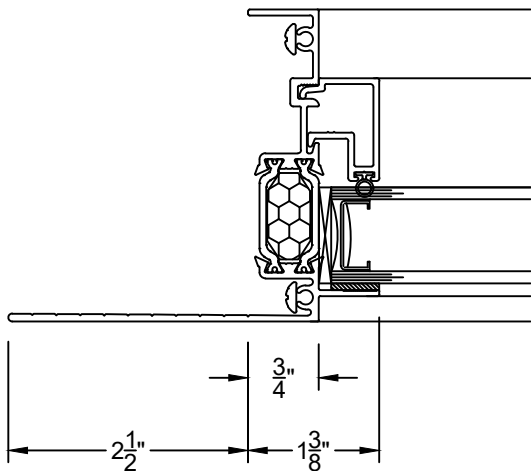

③B 2.5 FLANGE JAMB
2710

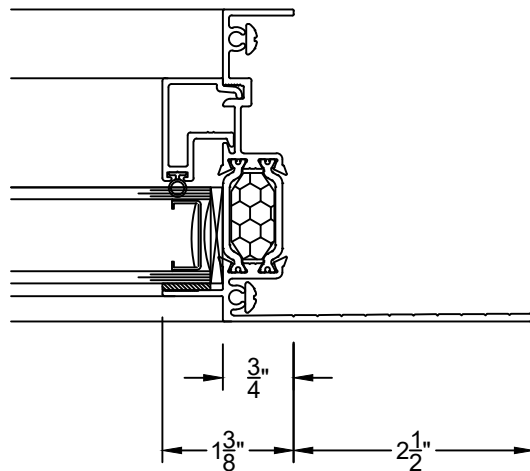

③B 2.5 FLANGE JAMB
2710

VER: 2024.07