

## SERIES 5100 FIXED WINDOWS

TEST SIZE W x H	AAMA RATING	AIR INFILTRATION	DESIGN PRESSURE	WATER RESISTANCE	U-VALUE	SHGC	VT
60" x 99"	AW-PG100	≤0.10 cfm/ft <sup>2</sup>	100 psf	12 psf	0.25-0.52	0.19-0.65	0.31-0.69

### TABLE OF CONTENT

- INTRODUCTION -P1
- SECTION DETAILS -P2
- MULLION -P3-P4
- MALE/FEMALE -P5
- 1-3/8" IGU FRAME -P5
- FACE FLANGE -P6-P7

### FEATURES

- ALUMINUM THERMAL-BREAK FIXED WINDOW
- 3-1/4" FRAME DEPTH
- 1" DOUBLE PANE INSULATED GLASS
- HEAVY DUTY EXTRUSION
- AAMA 2604 POWDER COAT PAINT

### OPTIONAL SELECTIONS

- LOW-E COATING & ARGON FILLED IGU
- FACE FLANGE WITH VARIOUS SIZE
- CUSTOM FINISH AND CUSTOM COLOR
- GRIDS
- LOUVER SYSTEM
- MALE/ FEMALE FRAME
- HEAVY DUTY MALE/ FEMALE FRAME
- 1-3/8" INSULATED GLASS
- OTHER OPTIONAL ACCESSORIES

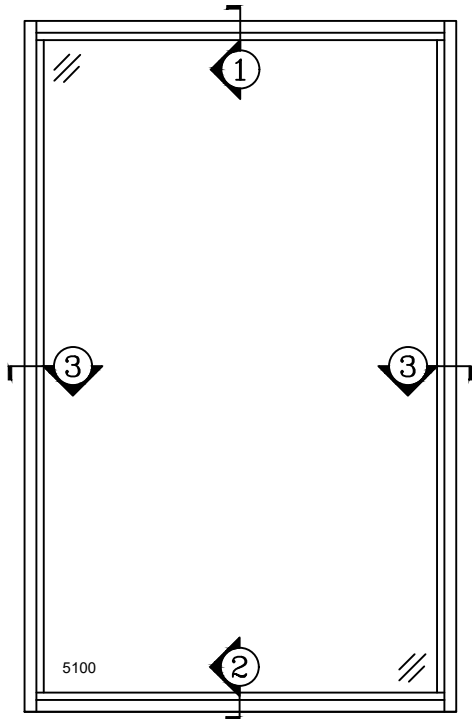

5100 FIXED WINDOW

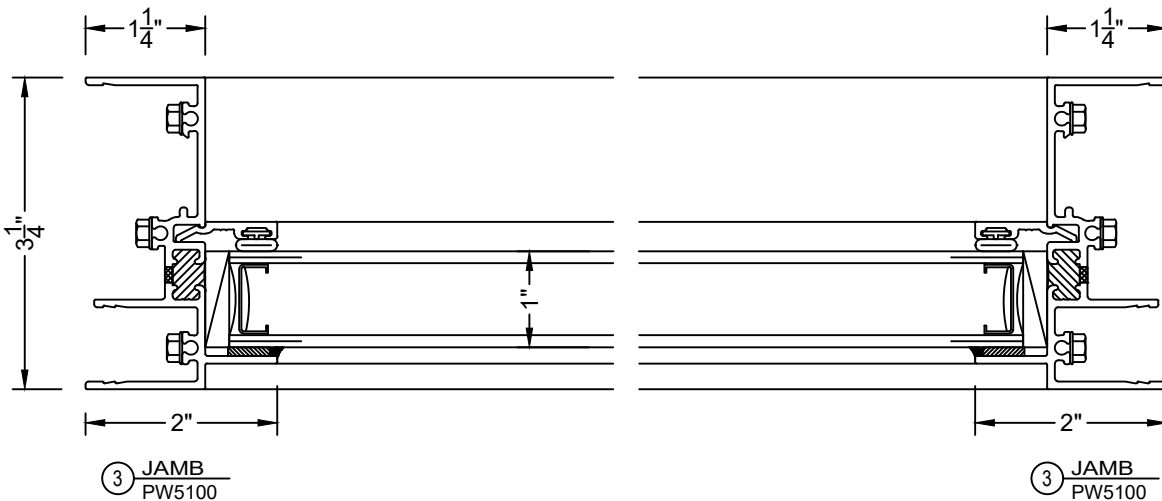
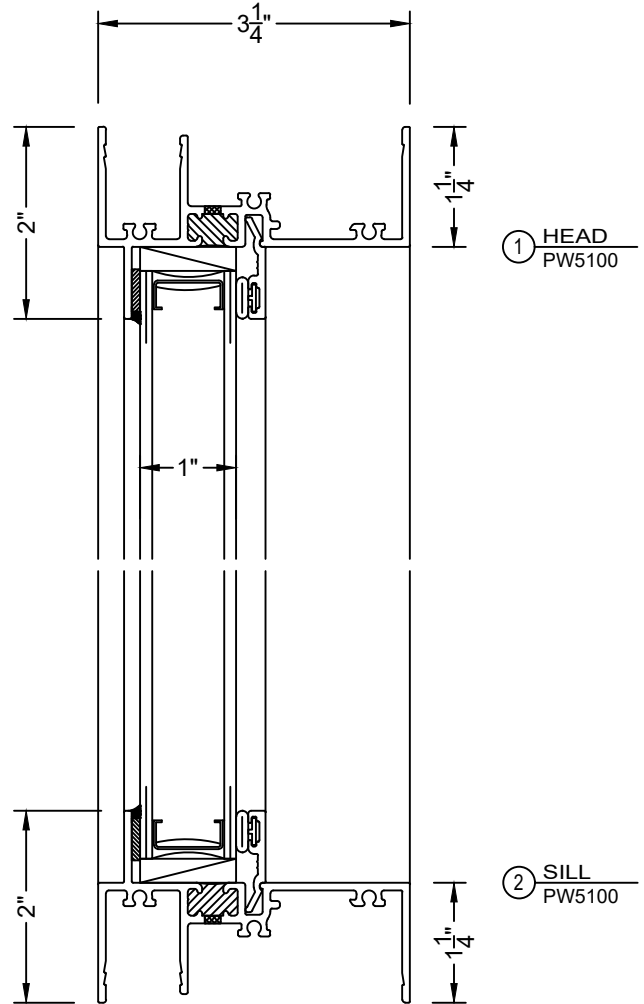

VER: 2020.03

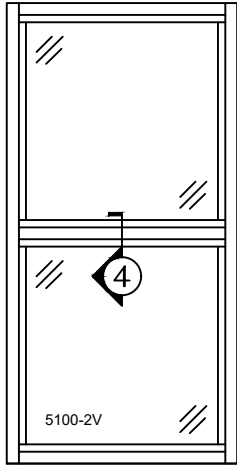

PW5100-2V VERTICAL 2 LITE

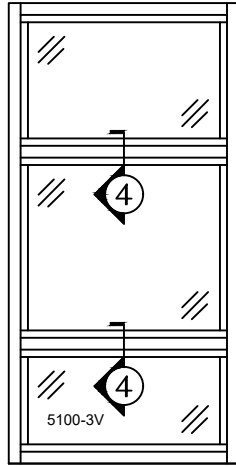

PW5100-3V VERTICAL 3 LITE

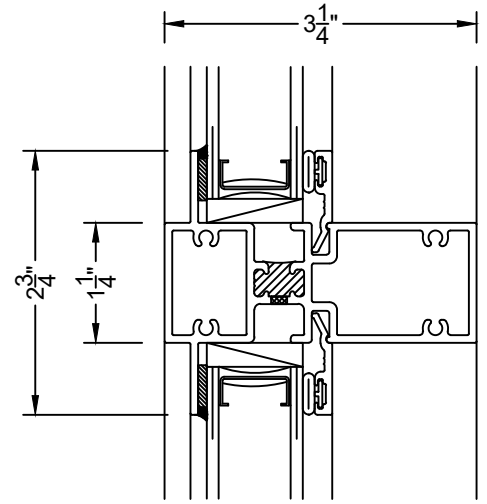

④ T IMPOST  
PW5100

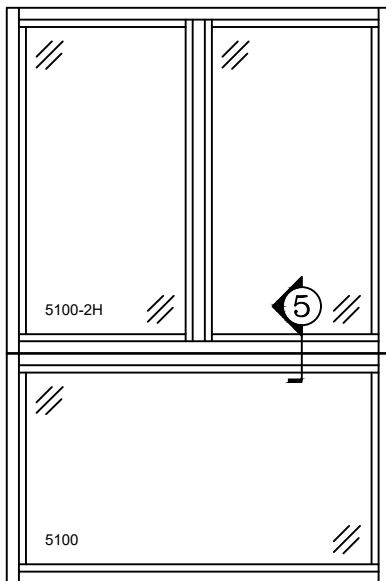

PW5100-2H OVER PW5100

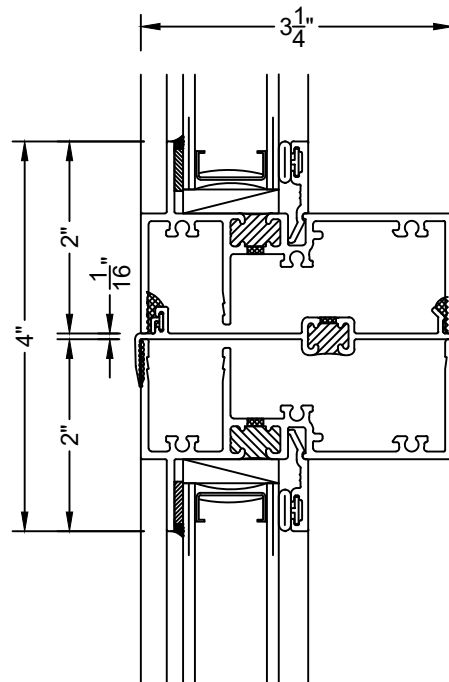

⑤ STACK MULLION  
PW5100 OVER PW5100

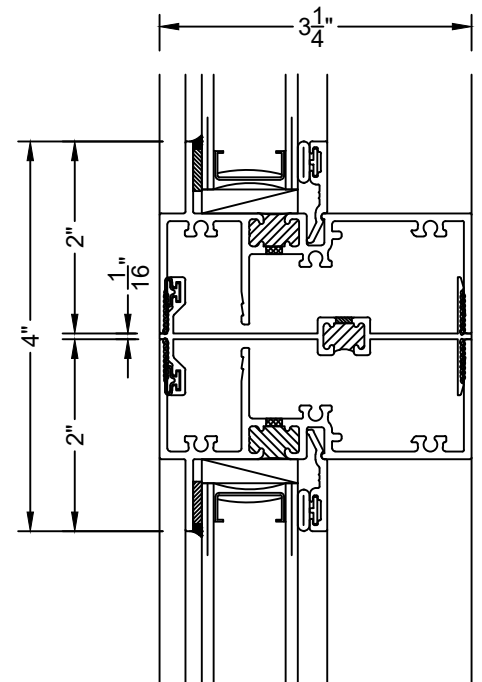

⑤A H MULLION  
PW5100 OVER PW5100

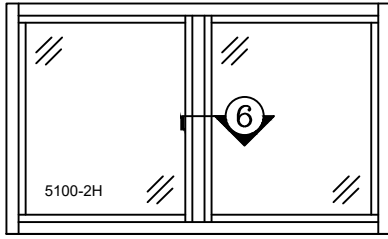

PW5100-2H HORIZONTAL 2 LITE

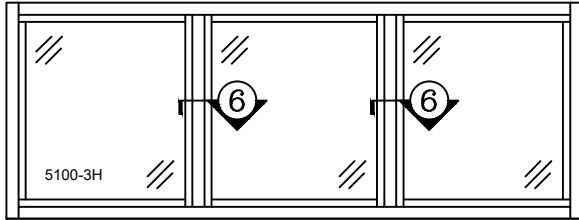

PW5100-3H HORIZONTAL 3 LITE

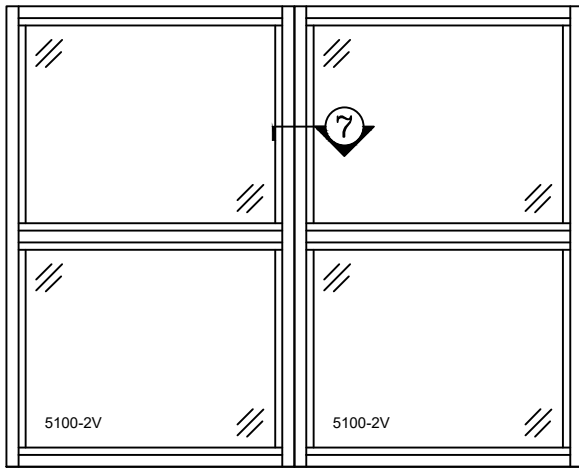

PW5100-2V & PW5100-2V WITH  
H MULLION

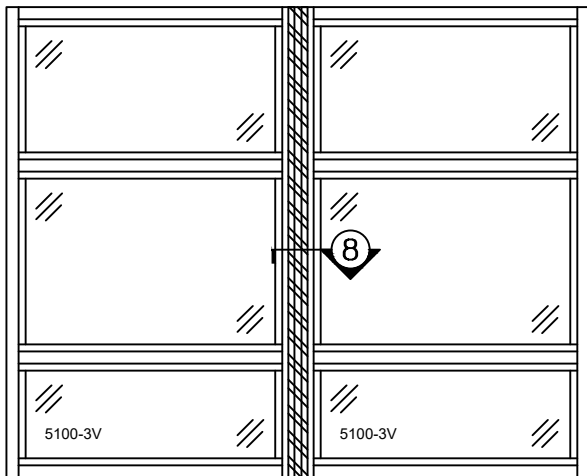

PW5100-3V & PW5100-3V WITH  
3PC MULLION

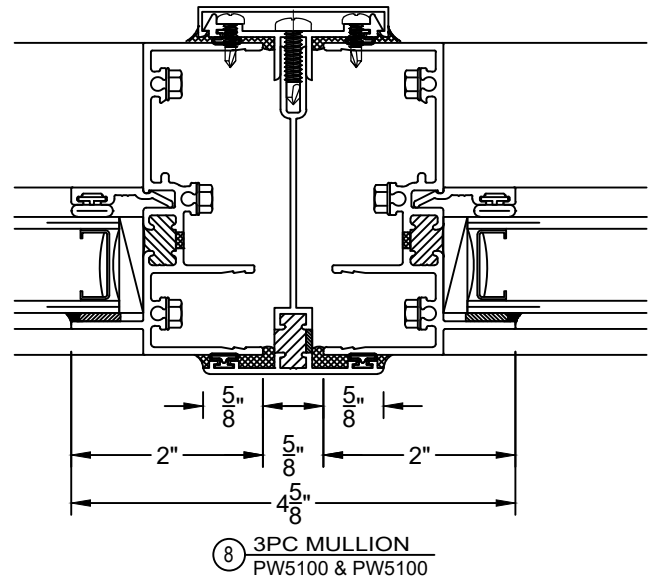
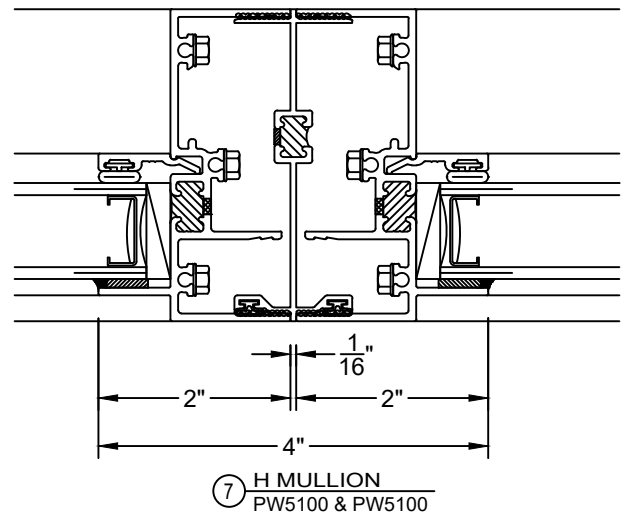
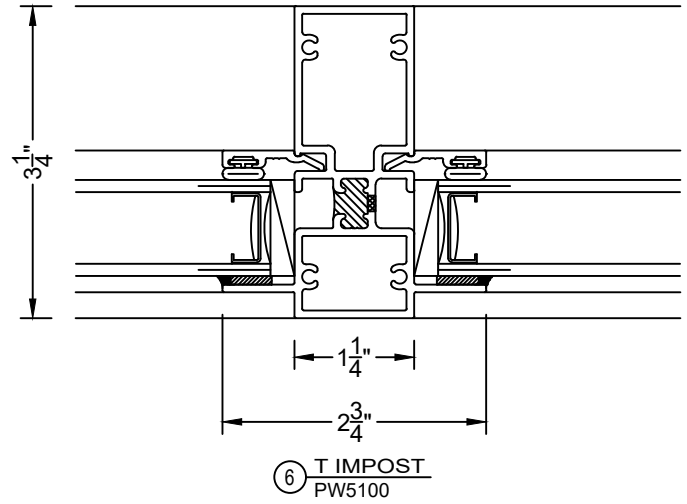

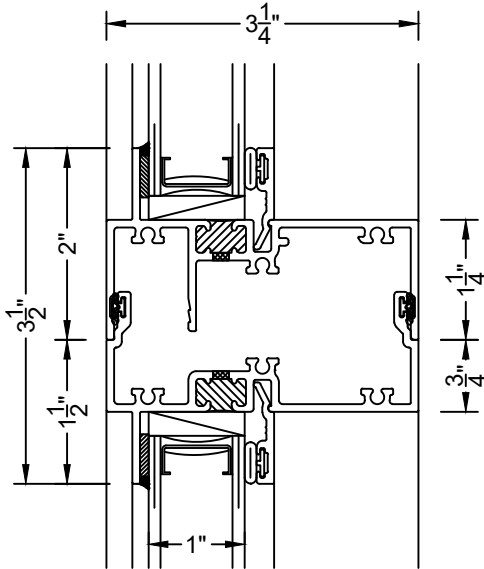

⑨ MALE / FEMALE FRAME  
PW5100

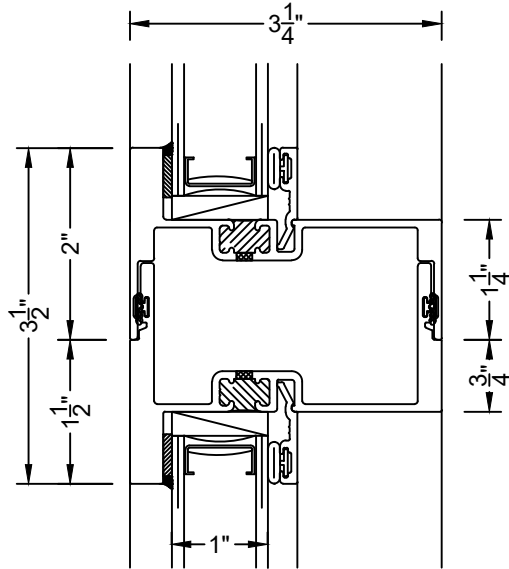

⑩ HEAVY DUTY MALE / FEMALE FRAME  
PW5100

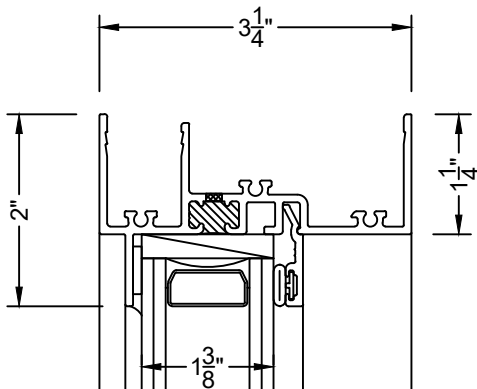

⑩ 1-3/8" IGU FRAME  
PW5100

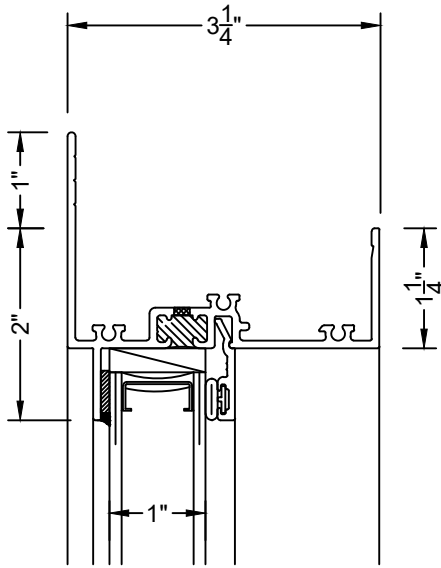

① 1" FLANGE HEAD/SILL  
PW5100

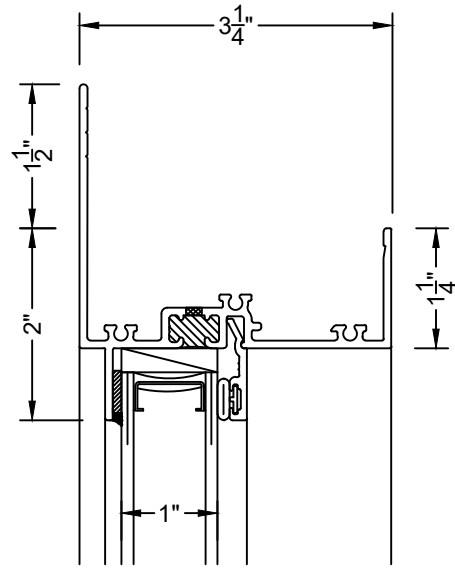

①A 1-1/2" FLANGE HEAD/SILL  
PW5100

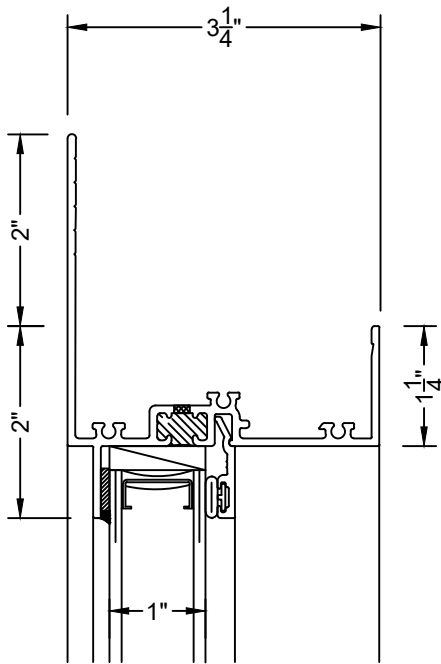

①B 2" FLANGE HEAD/SILL  
PW5100

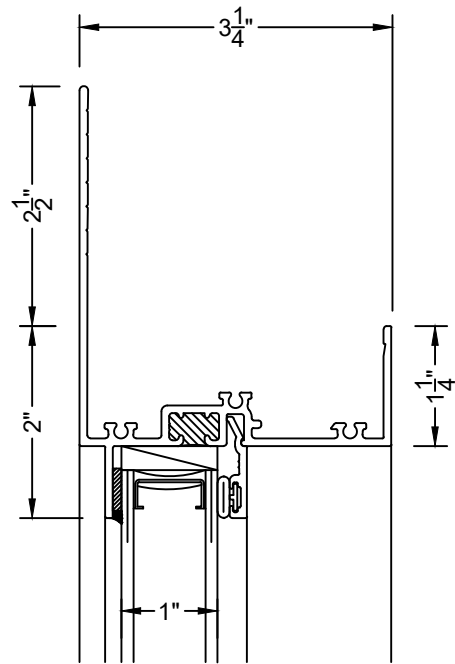

①C 2-1/2" FLANGE HEAD/SILL  
PW5100

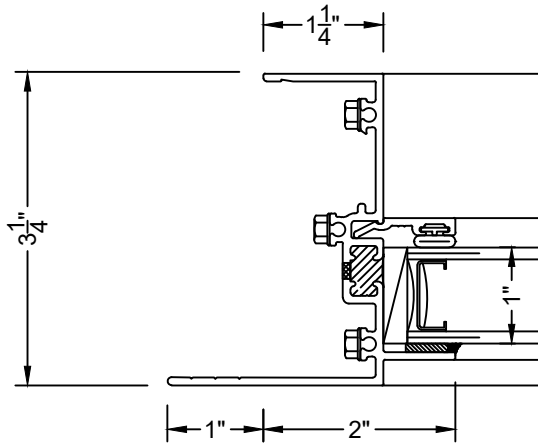

② 1" FLANGE JAMB  
PW5100

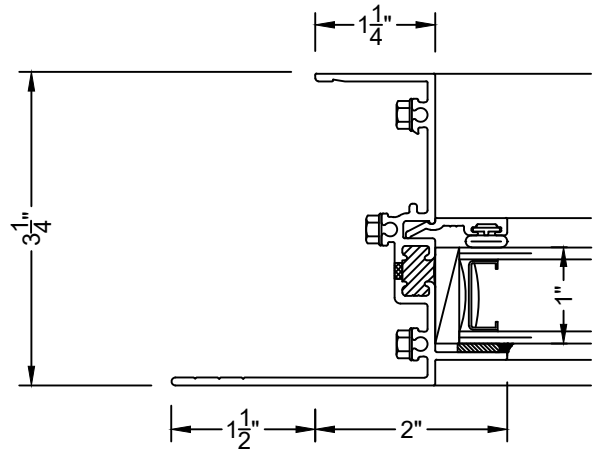

②A 1-1/2" FLANGE JAMB  
PW5100

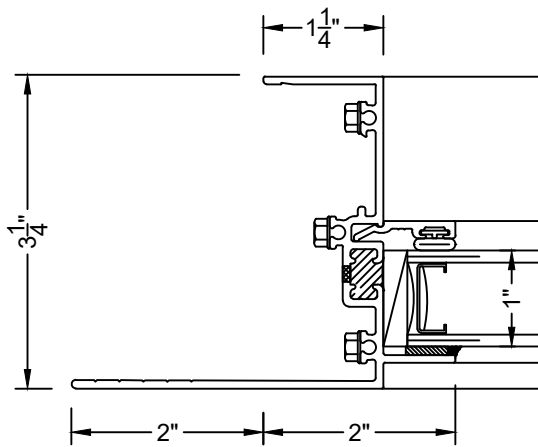

②B 2" FLANGE JAMB  
PW5100

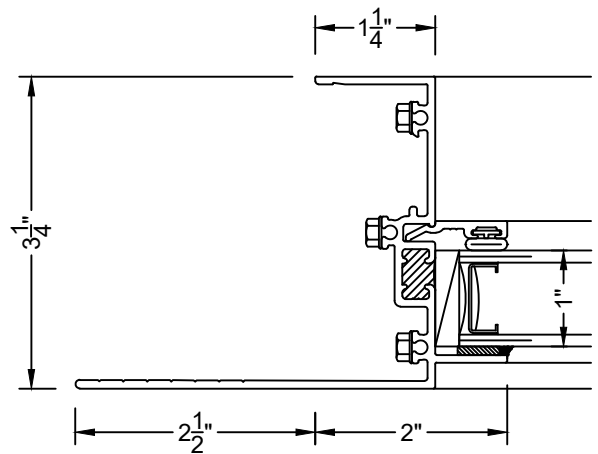

②C 2-1/2" FLANGE JAMB  
PW5100