

SERIES 9000A TILT & TURN WINDOW

TEST SIZE W X H	AAMA RATING	AIR INFILTRATION	DESIGN PRESSURE	WATER RESISTANCE	U- FACTOR	SHGC	VT
60" x 99"	AW-PG75	≤0.30 cfm/ft ²	75 psf	12 psf	0.35-0.52	0.19-0.55	0.42-0.6
48" x 80"	AW-PG100	≤0.30 cfm/ft ²	100 psf	12 psf			

TABLE OF CONTENT

- SECTION DETAILS -P2
- MATER FRAME -P3-P4
- MULLION -P5-P6

FEATURES

- ALUMINUM THERMAL-BREAK WINDOW
- DUAL-ACTION (TILT & TURN)
- 3-1/4" FRAME DEPTH
- 1-1/4" DOUBLE PANE INSULATED GLASS
- AAMA 2604 POWDER COAT PAINT
- HEAVY DUTY EXTRUSION
- POLYAMIDE THERMAL BARRIER
- EUROPEAN-STYLE FRAME & CORNER KEYS
- BUTT-TYPE HINGE
- TRIPLE GASKET SEAL
- PRESSURE-EQUALIZED DESIGN
- ZERO-SIGHTLINE SASH
- LEVER HANDLE ON INTERIOR SASH

OPTIONAL SELECTIONS

- LOW-E COATING & ARGON FILLED IGU
- CUSTOM FINISH AND CUSTOM COLOR
- GRIDS
- FULL SCREEN
- LIMIT DEVICE
- HANDLE WITH KEY LOCK
- OTHER OPTIONAL ACCESSORIES

VER: 2020.03

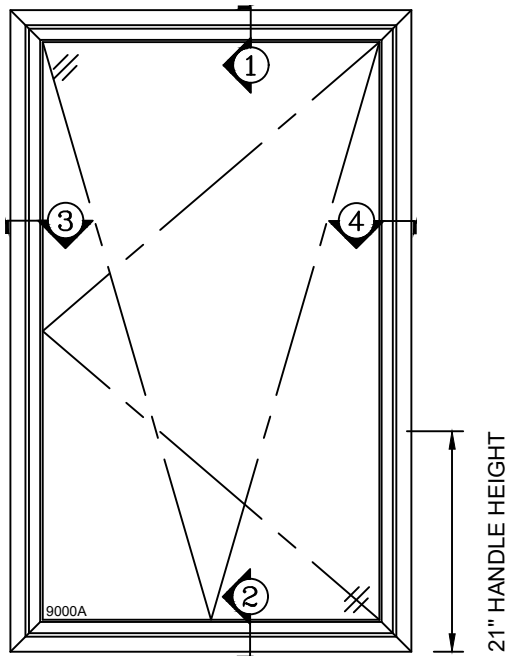

9000A TILT & TURN WINDOW

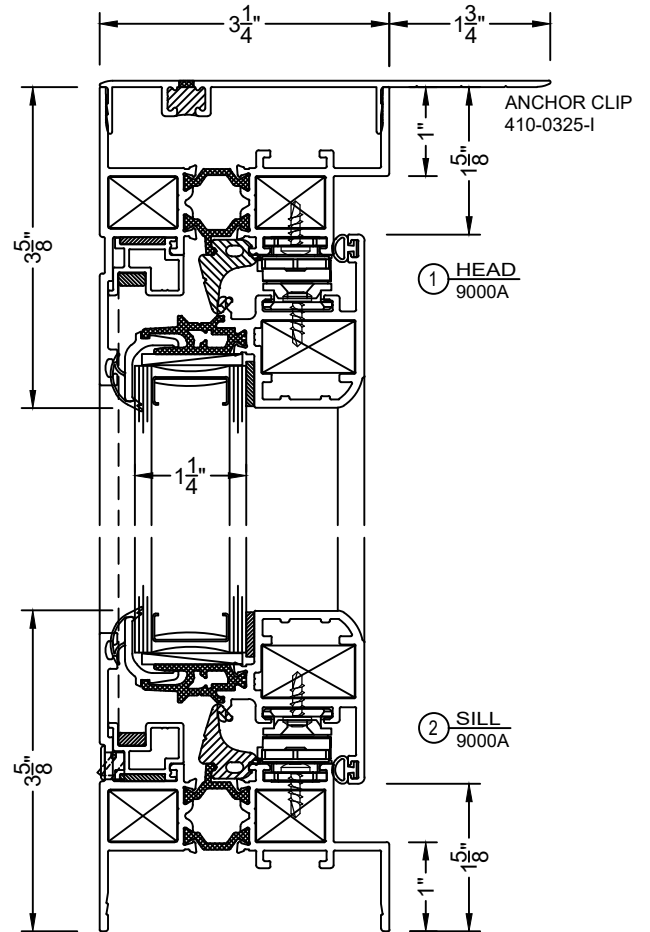

1 HEAD 9000A

2 SILL 9000A

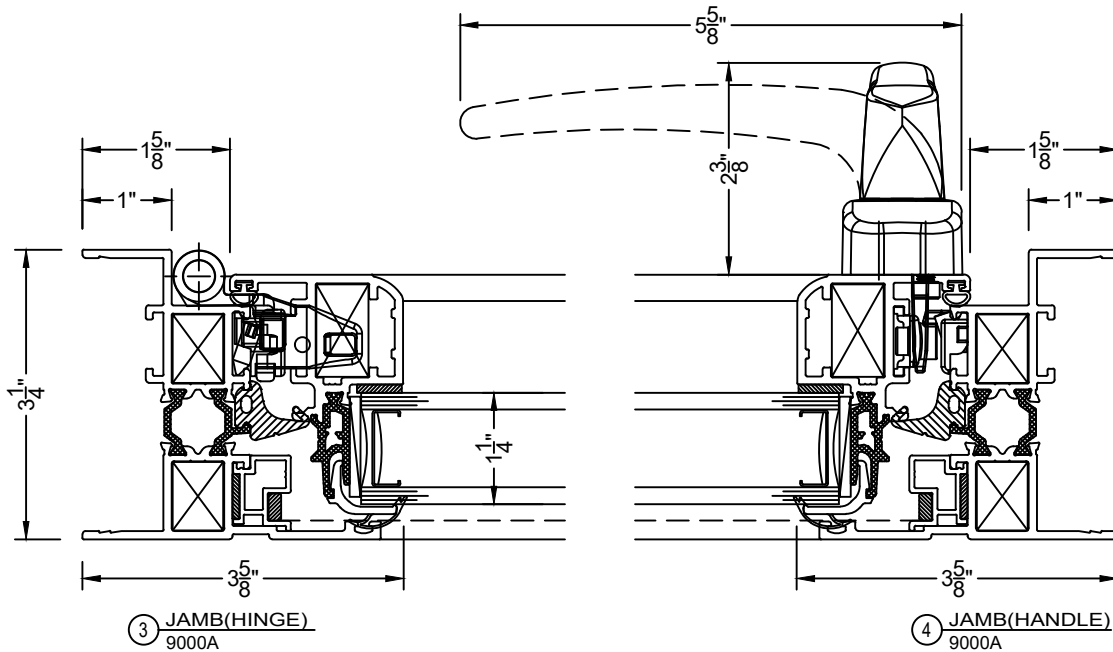

3 JAMB(HINGE) 9000A

4 JAMB(HANDLE) 9000A

VER: 2020.03

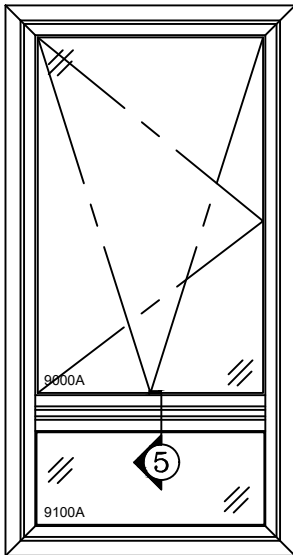

9000A-2V TILT & TURN OVER FIXED

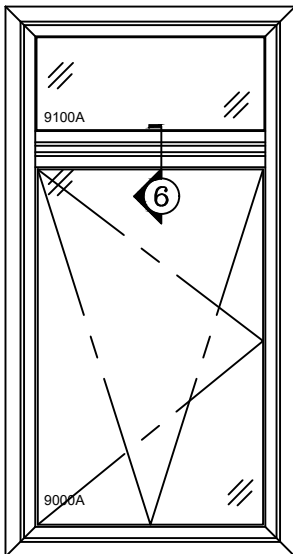
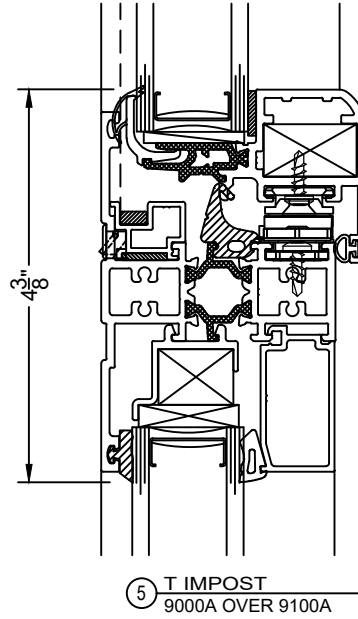

9000A-2V FIXED OVER TILT & TURN

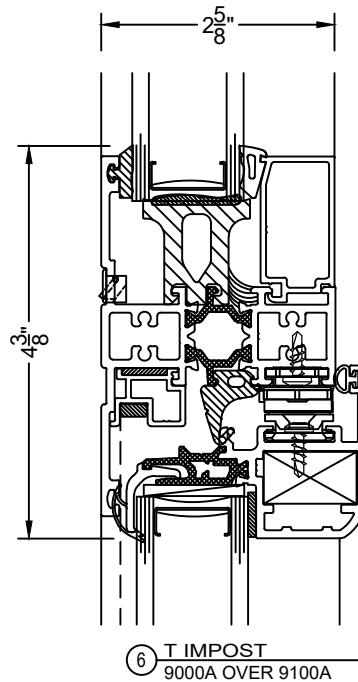

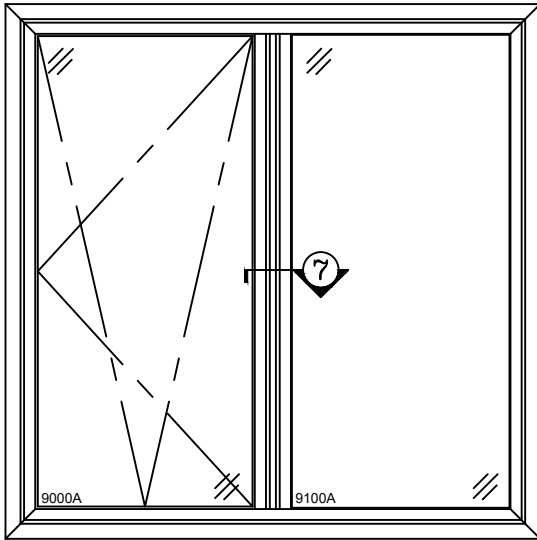

9000A-2H TILT & TURN & FIXED

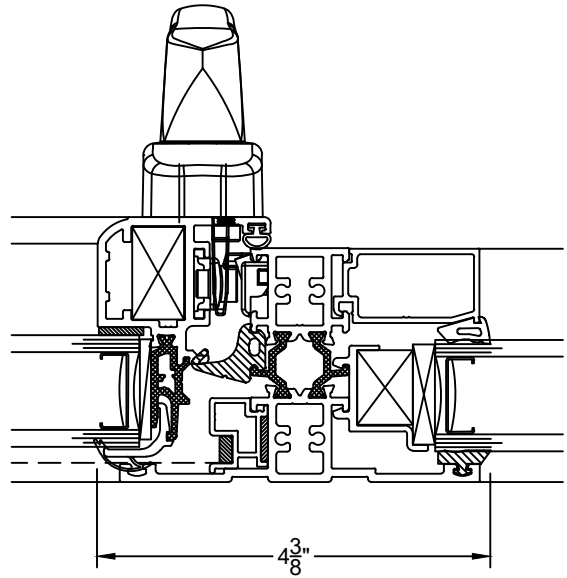

⑦ T IMPOST
9000A & 9100A

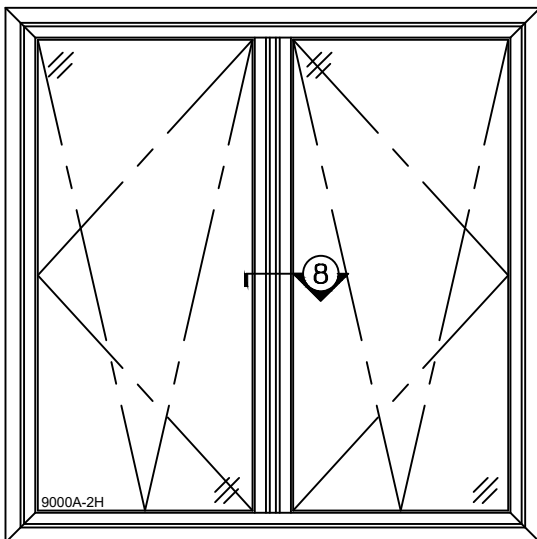

9000A-2H TWIN TILT & TURN

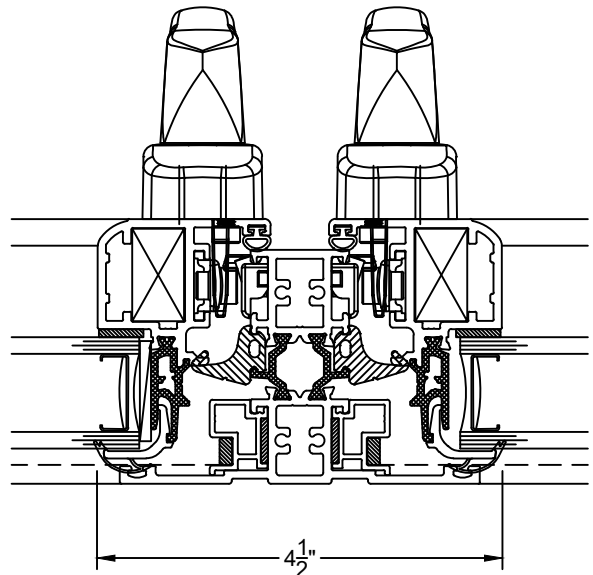

⑧ T IMPOST
9000A & 9000A

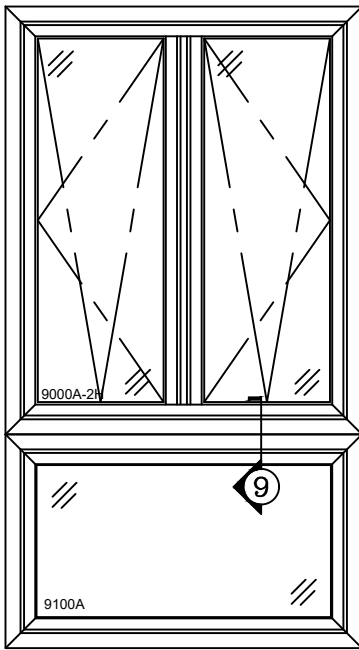

9000A-2H TWIN OVER 9100A

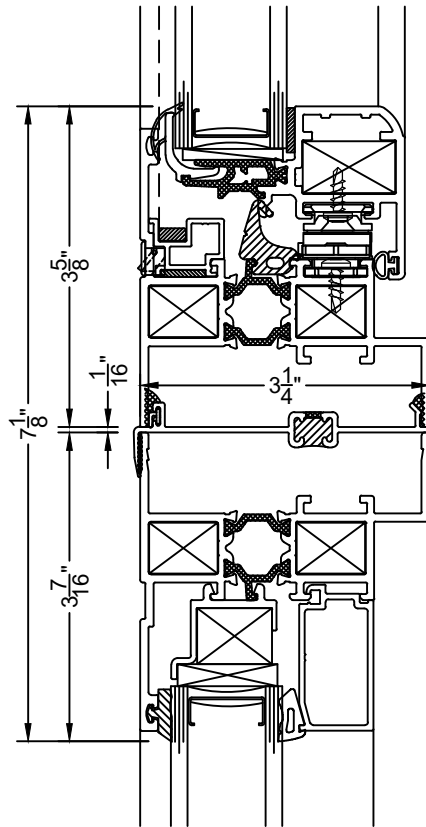

9 STACK MULLION
9000A OVER 9100A

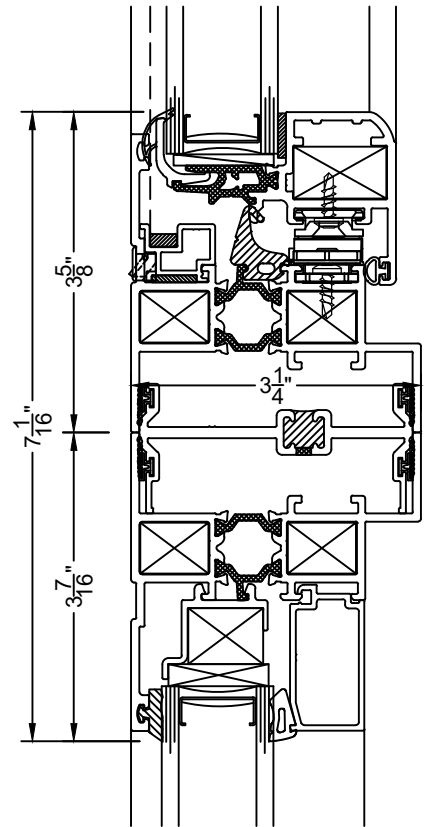

9A H MULLION
9000A OVER 9100A

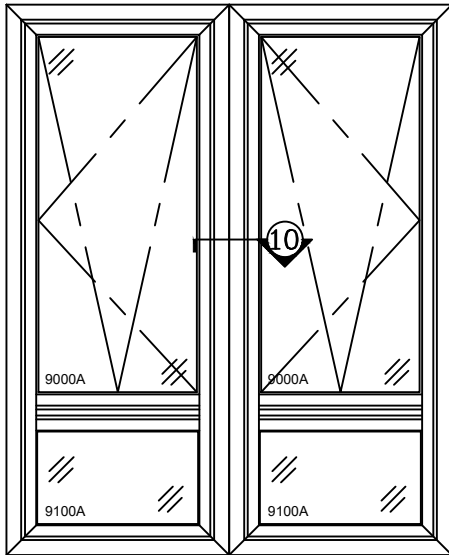

9000A-2V & 9000A-2V WITH H MULLION

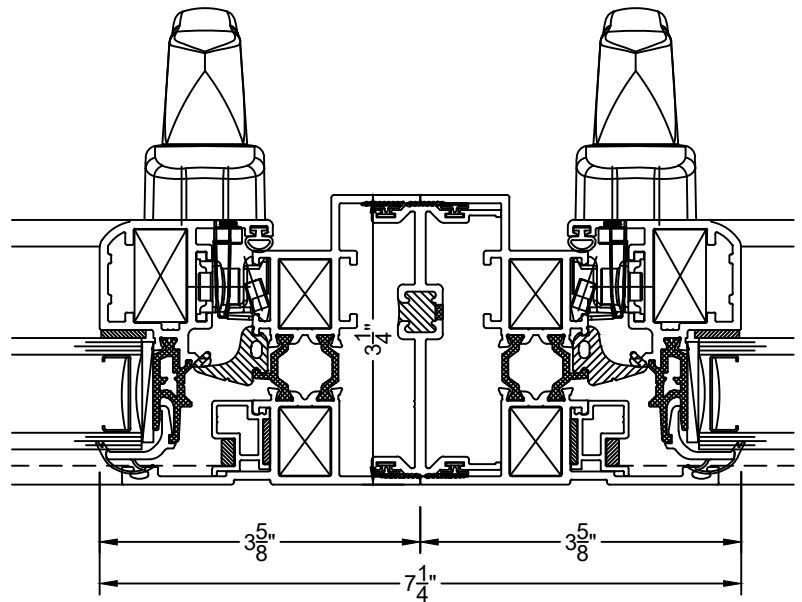

10 H MULLION
9000A & 9000A

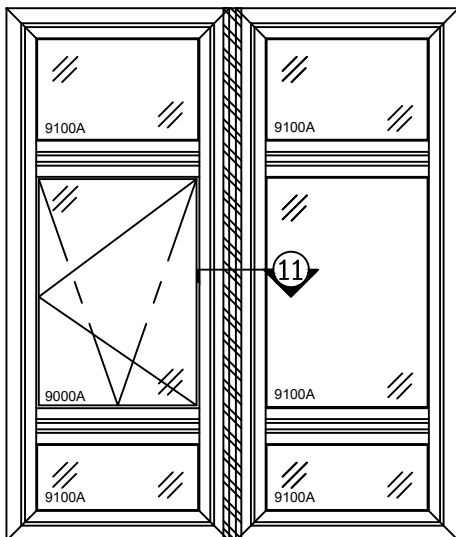

9000A-3V & 9100A-3V WITH 3PC MULLION

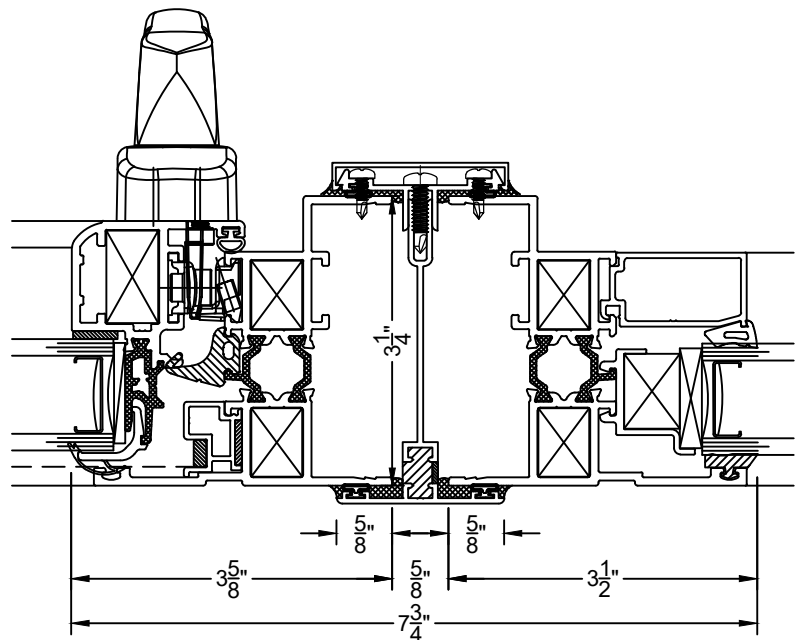

11 3PC MULLION
9000A & 9100A